

Interference suppression film capacitors

MKP 335 5

MKP RADIAL POTTED TYPE

PITCH 15/22.5 mm

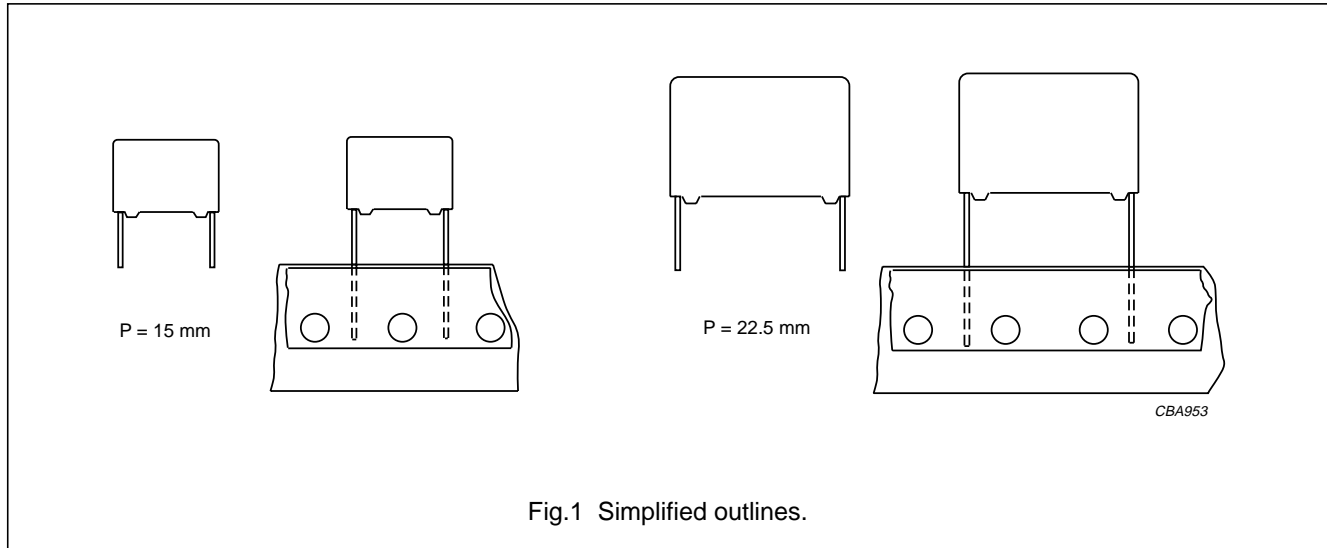

Fig.1 Simplified outlines.

FEATURES

- 15 to 22.5 mm lead pitch
- Supplied loose in box and taped on reel
- Consists of a low-inductive wound cell of metallized polypropylene film, potted in a flame-retardant case.

APPLICATIONS

- For X2 electromagnetic interference suppression
- Specially designed to meet the NEW REQUIREMENTS of the new "IEC 60384-14 2nd edition and EN 132400", requiring a 2.5 kV peak pulse voltage test and both UL1414 and CSA-C22.2 No. 1 specifications.

DETAIL SPECIFICATION

For more detailed data and test requirements see "Tentative detail specification HQX-48-300-188".

QUICK REFERENCE DATA

DESCRIPTION	VALUE
Capacitance range (E12 series)	10 nF to 0.47 μ F
Capacitance tolerance	\pm 20%; \pm 10%; \pm 5%
Rated (AC) voltage, 50 to 60 Hz	275 V
Rated (DC) voltage	630 V
Climatic category	55/100/56/B
Rated temperature	100 °C
Maximum application temperature	100 °C
Reference specifications	IEC 60384-14 2 nd edition and EN 132400
Safety approvals:	
250 V	UL1414; CSA-C22.2 No. 1; note 2
275 V	UL1283; CSA-C22.2 No. 8; CCEE; note 1 SEV; VDE; FI; N; D; S; IMQ; ÖVE; note 2
Materials	qualified in accordance with UL94V-O
Safety class	X2













Notes

1. Pending.
2. Approved.

Interference suppression film capacitors

MKP 335 5

SAFETY APPROVALS

SAFETY APPROVALS (X2)		VOLTAGE	VALUE	FILE NUMBERS
	UL1414	250 V (AC)	10 nF to 1.0 μ F	E 112471
	UL1283	275 V (AC)	10 nF to 1.5 μ F	pending
	CSA-C22.2 No.1	250 V (AC)	10 nF to 1.0 μ F	LR94054-16
	CSA-C22.2 No.8	275 V (AC)	10 nF to 1.5 μ F	pending
	SEV (EN132400)	275 V (AC)	10 nF to 1.5 μ F	99.6 60019.01
	VDE (EN132400)	275 V (AC)	10 nF to 1.5 μ F	118878
	FI (EN132400)	275 V (AC)	10 nF to 1.5 μ F	FI 12134
	NEMKO (EN132400)	275 V (AC)	10 nF to 1.5 μ F	P99100002
	DEMKO (EN132400)	275 V (AC)	10 nF to 1.5 μ F	308307
	SEMKO (EN132400)	275 V (AC)	10 nF to 1.5 μ F	9851035/01
	IMQ (EN132400)	275 V (AC)	10 nF to 1.5 μ F	V4696
	ÖVE (EN132400)	275 V (AC)	10 nF to 1.5 μ F	E260-010-00
	CCEE	275 V (AC)	10 nF to 1.5 μ F	pending

Interference suppression film capacitors

MKP 335 5

COMPOSITION OF CATALOGUE NUMBER

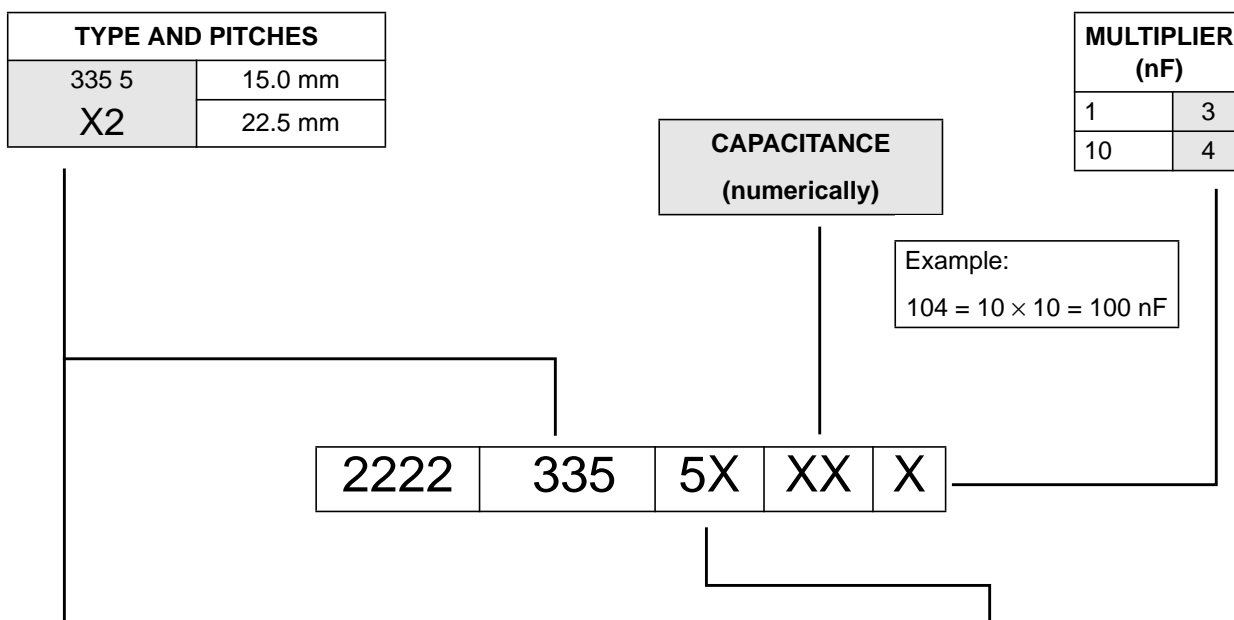

TYPE	PACKAGING ⁽¹⁾	LEAD CONFIGURATION	C-TOL	PREFERRED TYPES
335 5 X2	loose in box	lead length 3.5 mm	±20%	2222 335 50...
		lead length 25.0 mm		2222 335 54...
				ON REQUEST
335 5 X2	loose in box	lead length 3.5 mm	±10%	2222 335 51...
		lead length 5.0 mm	±20%	2222 335 56...
			±10%	2222 335 57...
		lead length 25.0 mm	±10%	2222 335 55...
	taped on reel	H = 18.5 mm; note 2	±20%	2222 335 52...
	±10%		2222 335 53...	

Notes

1. For SPQ refer to this handbook, chapter "Packaging information".
2. H = in-tape height; for detailed specifications refer to this handbook, chapter "Packaging information".

Interference suppression film capacitors

MKP 335 5

MKP 335 5 GENERAL DATA

PITCH 15/22.5 mm

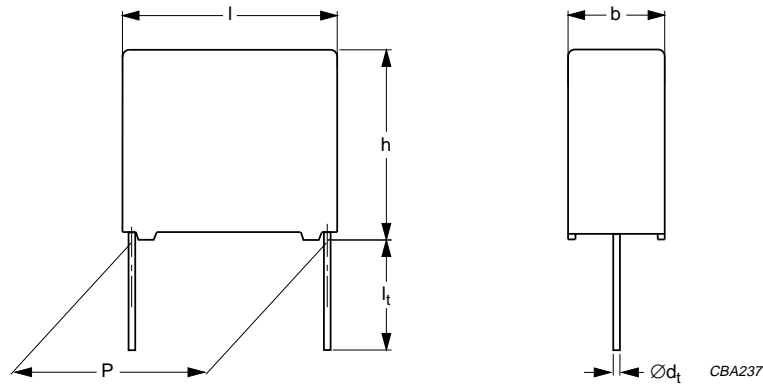

Fig.3 Outline.

Specific reference data for the 275 V AC capacitors

DESCRIPTION	VALUE	
	at 10 kHz	at 100 kHz
Tangent of loss angle: C ≤ 100 nF 100 nF < C ≤ 470 nF	≤ 10 × 10 ⁻⁴ ≤ 20 × 10 ⁻⁴	≤ 30 × 10 ⁻⁴ ≤ 70 × 10 ⁻⁴
Rated voltage pulse slope (dU/dt) _R at 390 V (DC)	100 V/μs	
R between leads, for C ≤ 0.33 μF at 100 V; 1 minute	>15000 MΩ	
RC between leads, for C > 0.33 μF at 100 V; 1 minute	>5000 s	
R between leads and case; 100 V; 1 minute	>30000 MΩ	
Withstanding voltage DC (cut off current 10 mA); rise time 100 V/s	2200 V; 1 minute	
Withstanding voltage AC between leads and case	2050 V; 1 minute	

Interference suppression film capacitors

MKP 335 5

 $U_{Rac} = 275 \text{ V (AC) X2}$; $U_{Rdc} = 630 \text{ V}$

C (μF)	DIMENSIONS $b \times h \times l$ (mm)	MASS (g)	CATALOGUE NUMBER	
			LOOSE IN BOX	
			short leads	long leads
			$l_t = 3.5 \pm 0.5 \text{ mm}$	$l_t = 25.0 \pm 2.0 \text{ mm}$
			C-tol = $\pm 20\%$	
		catalogue number ⁽¹⁾	last 5 digits ⁽¹⁾	
Pitch = $15.0 \pm 0.4 \text{ mm}$; $d_t = 0.80 \pm 0.08 \text{ mm}$				
0.01	5.0 × 11.0 × 17.5	1.2	2222 335 50103	.. 54103
0.015			2222 335 50153	.. 54153
0.022			2222 335 50223	.. 54223
0.033			2222 335 50333	.. 54333
0.047	6.0 × 12.0 × 17.5	1.4	2222 335 50473	.. 54473
0.068	7.0 × 13.5 × 17.5	1.9	2222 335 50683	.. 54683
0.1	8.5 × 15.0 × 17.5	2.6	2222 335 50104	.. 54104
0.15	10.0 × 16.5 × 17.5	3.1	2222 335 50154	.. 54154
Pitch = $22.5 \pm 0.4 \text{ mm}$; $d_t = 0.80 \pm 0.08 \text{ mm}$				
0.22	8.5 × 18.0 × 26.0	4.4	2222 335 50224	.. 54224
0.33	10.0 × 19.5 × 26.0	5.5	2222 335 50334	.. 54334
0.47	12.0 × 22.0 × 26.0	7.8	2222 335 50474	.. 54474

Note

1. The shading indicates preferred types.

Interference suppression film capacitors

MKP 335 5

CONSTRUCTION**Description**

- Low-inductive wound cell of metallized polypropylene (PP) film, potted with epoxy resin in a flame-retardant polypropylene case
- Radial leads, solder-coated:
 - Copper clad steel wire for pitch = 15 mm
 - Copper wire for pitch = 22.5 mm
- Small stand-off pips allow removal of solder flux etc. during cleaning of the printed-circuit board.

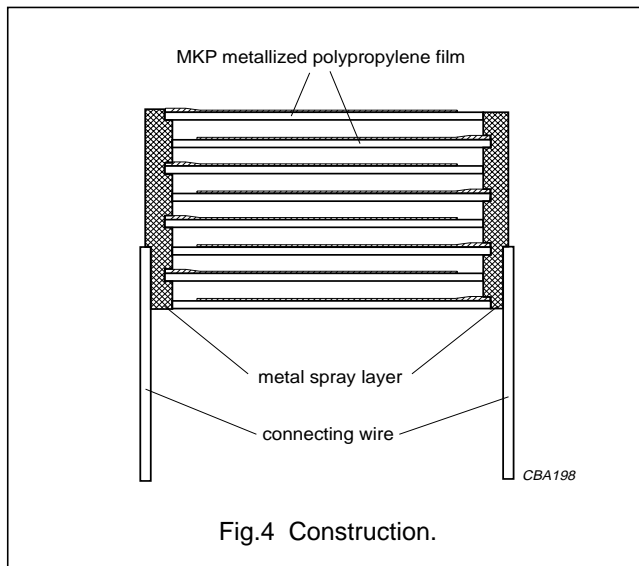
**Mounting****NORMAL USE**

The capacitors are designed for mounting on printed-circuit boards. The capacitors packed in bandoliers are designed for mounting on printed-circuit boards by means of automatic insertion machines. For detailed tape specifications refer to this handbook, chapter "Packaging information".

SPECIFIC METHOD OF MOUNTING TO WITHSTAND VIBRATION AND SHOCK

In order to withstand vibration and shock tests, it must be ensured that the stand-off pips are in good contact with the printed-circuit board:

- For pitches ≤ 15 mm capacitors shall be mechanically fixed by the leads.
- For larger pitches the capacitors shall be mounted in the same way and the body clamped.

SPACE REQUIREMENTS ON PRINTED-CIRCUIT BOARD

The maximum length and width of film capacitors is shown in Fig.5:

- Eccentricity as in Fig.5. The maximum eccentricity is smaller than or equal to the lead diameter of the product concerned.
- Product height with seating plane as given by "IEC 60717" as reference: $h_{\max} \leq h + 0.3$ mm.

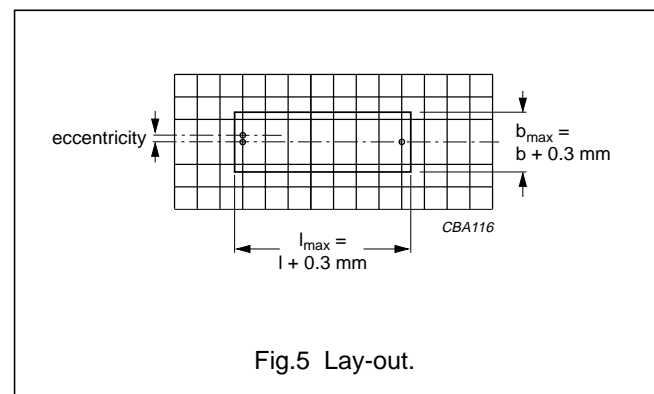
**Storage temperature**

- Storage temperature: $T_{\text{stg}} = -25$ to $+40$ °C with RH maximum 80% without condensation.

RATINGS AND CHARACTERISTICS REFERENCE CONDITIONS

Unless otherwise specified, all electrical values apply to an ambient temperature of 23 ± 1 °C, an atmospheric pressure of 86 to 106 kPa and a relative humidity of $50 \pm 2\%$.

For reference testing, a conditioning period shall be applied over 96 ± 4 hours by heating the products in a circulating air oven at the rated temperature and a relative humidity not exceeding 20%.

Interference suppression film capacitors

MKP 335 5

CHARACTERISTICS

Capacitance

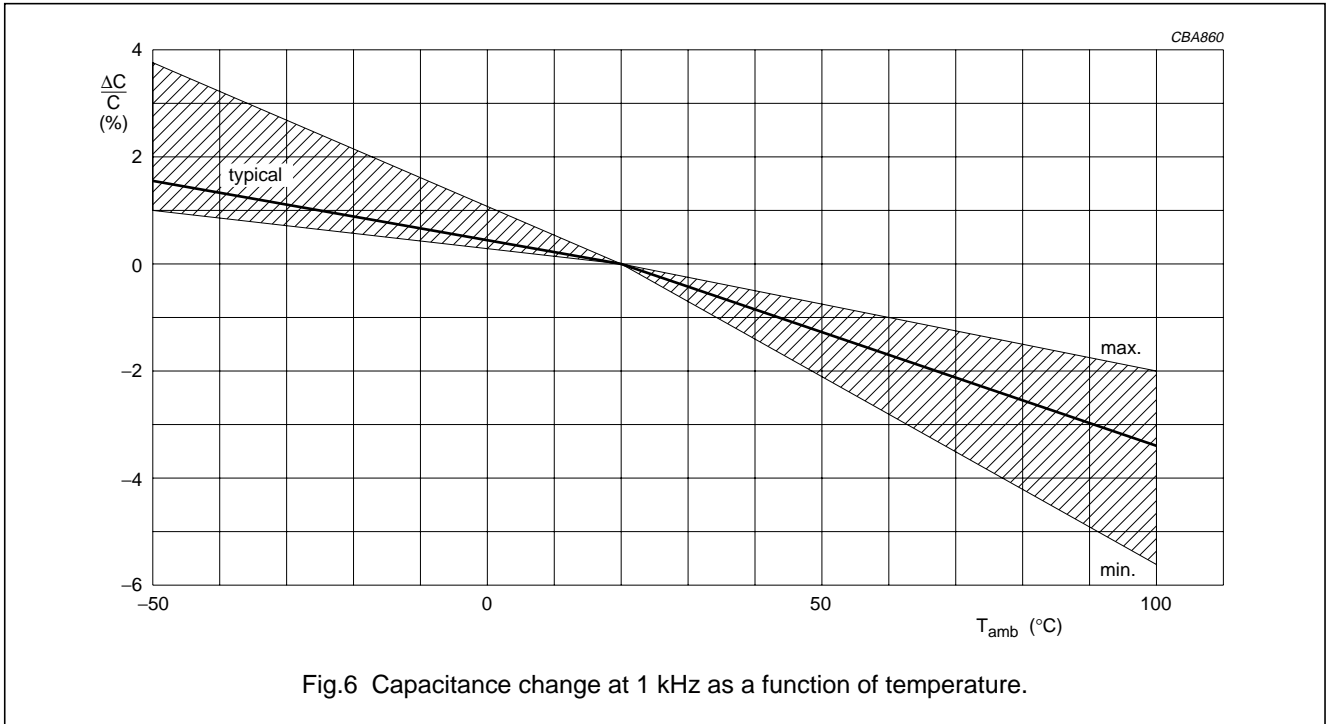

Tangent of loss angle

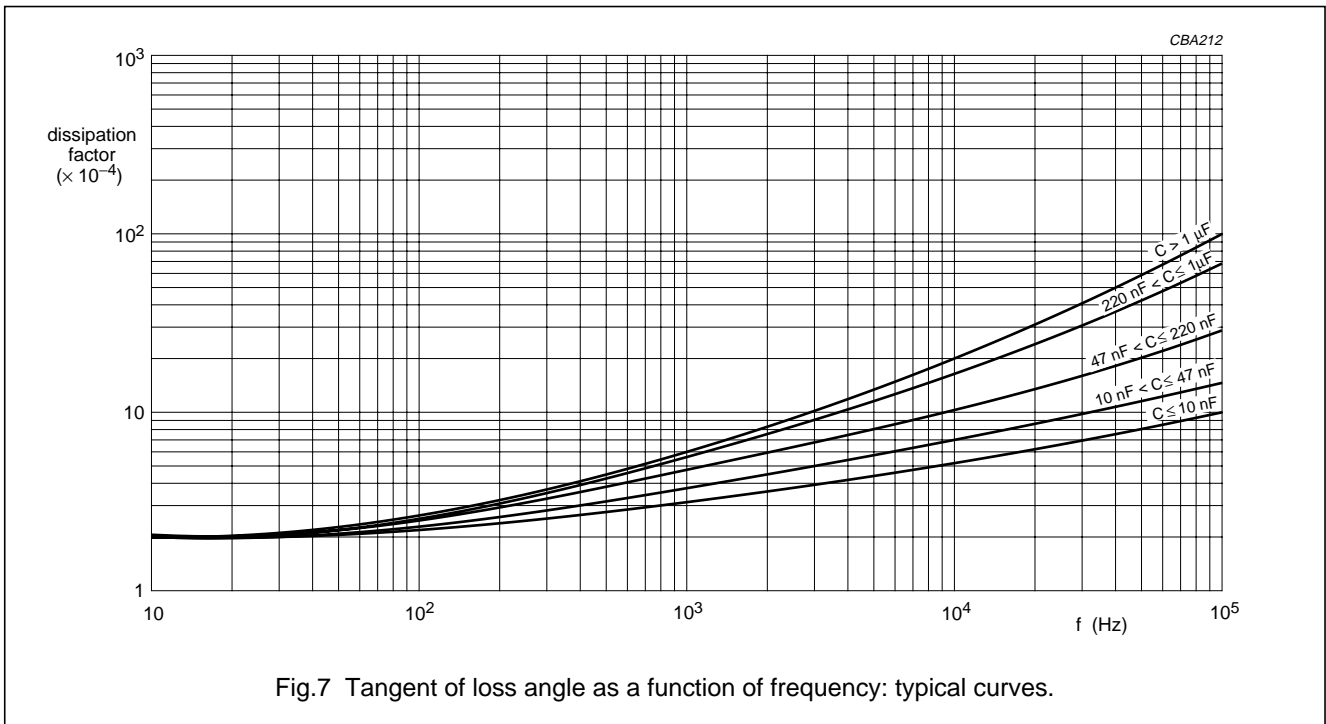

Interference suppression film capacitors

MKP 335 5

Impedance

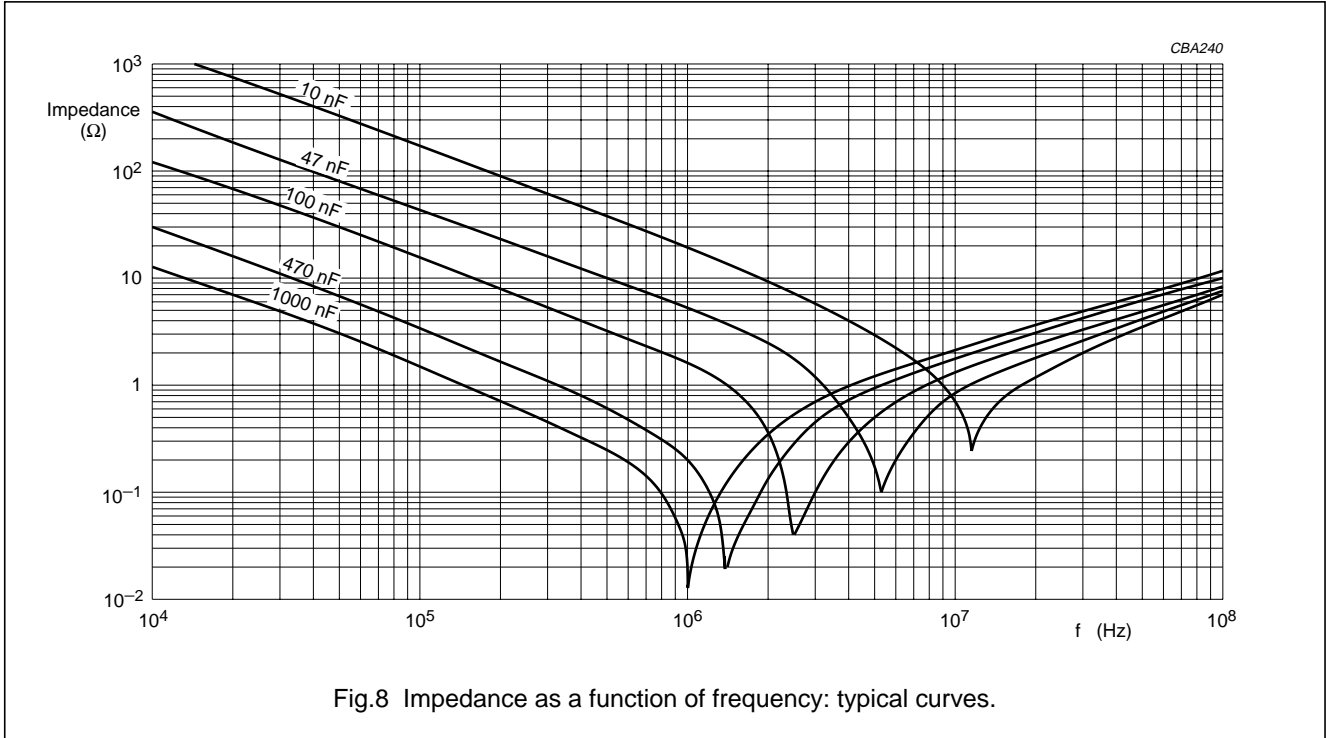

Resonant frequency

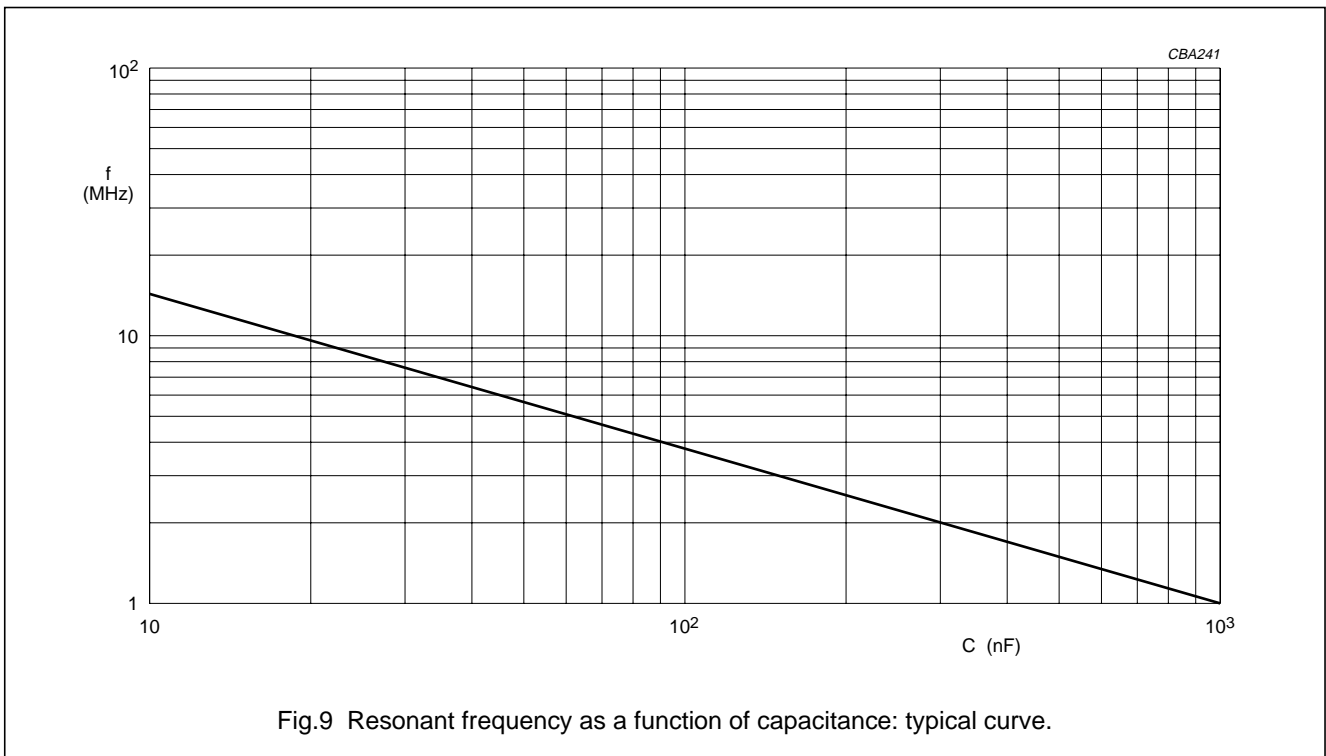

Interference suppression film capacitors

MKP 335 5

Maximum RMS voltage and AC current (sinewave) as a function of frequency for $T_{amb} \leq 100\text{ }^{\circ}\text{C}$

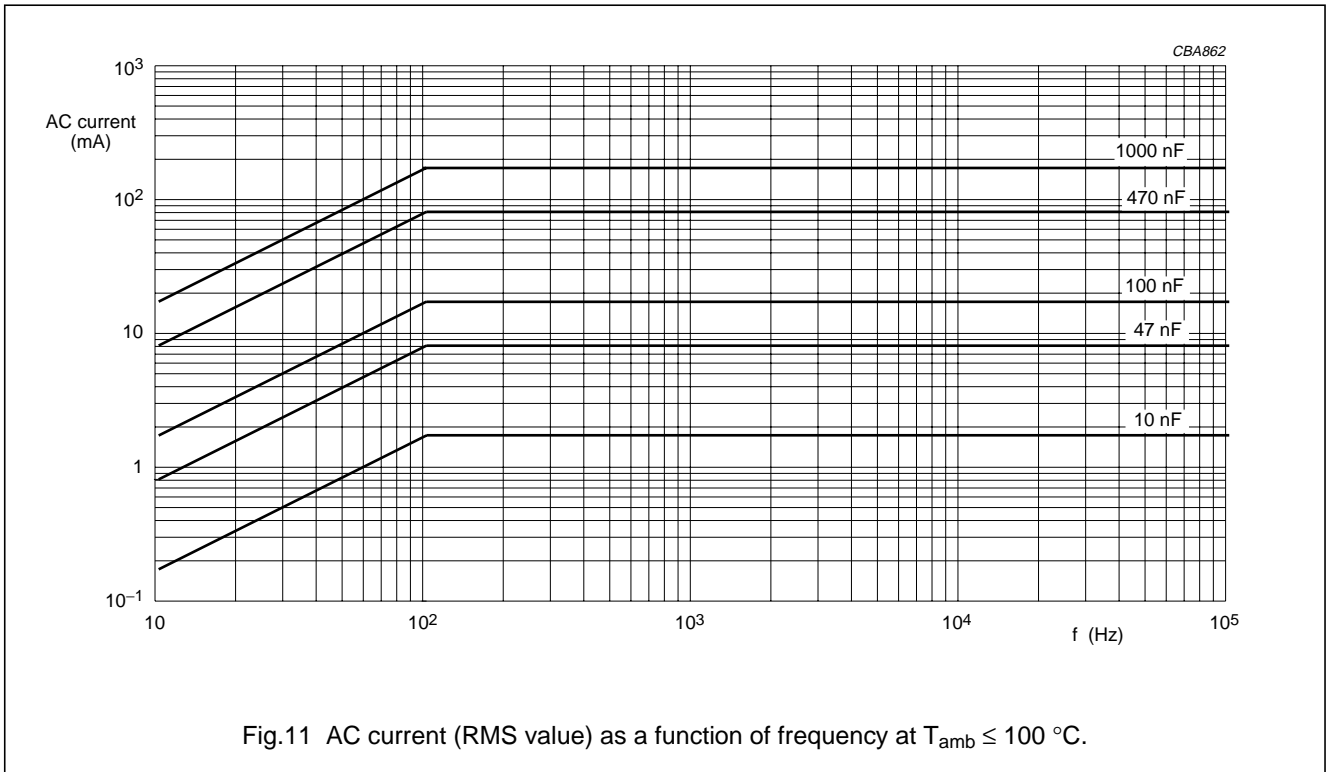
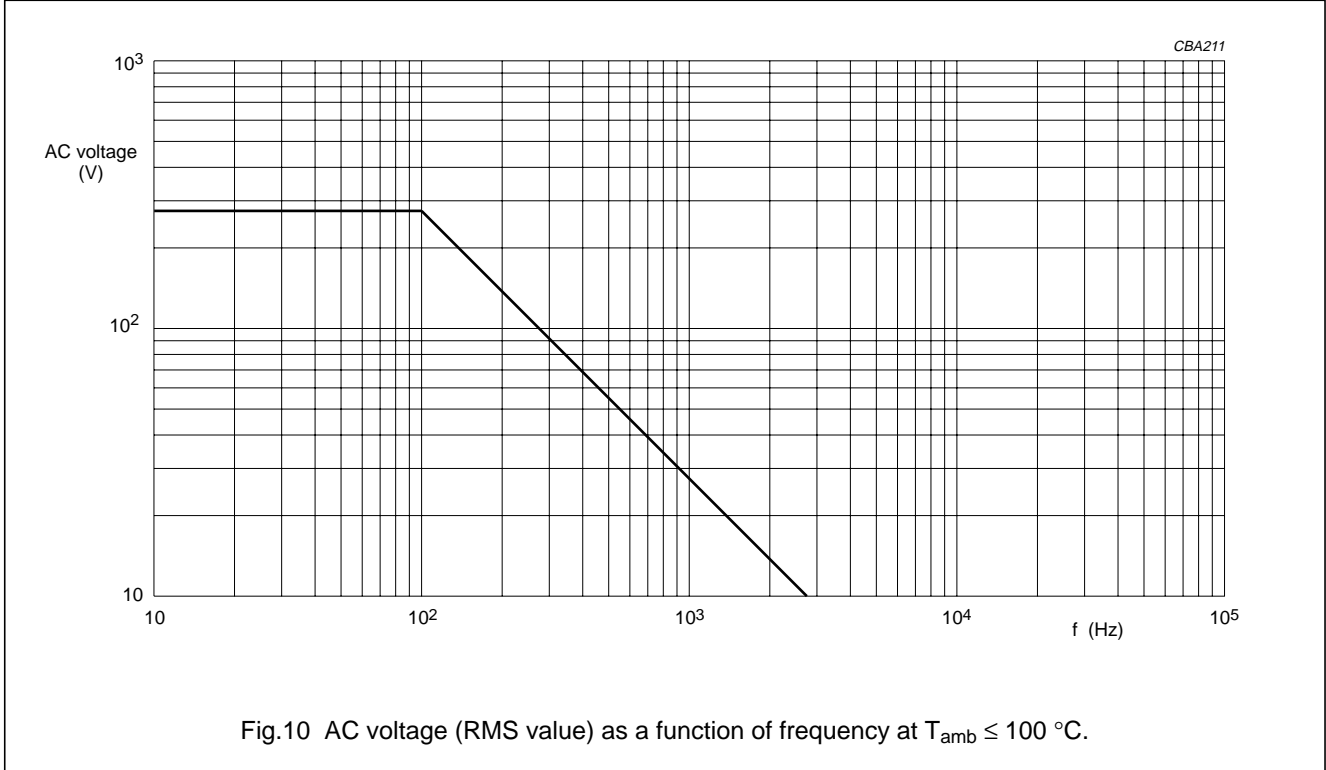

Interference suppression film capacitors

MKP 335 5

Insulation resistance

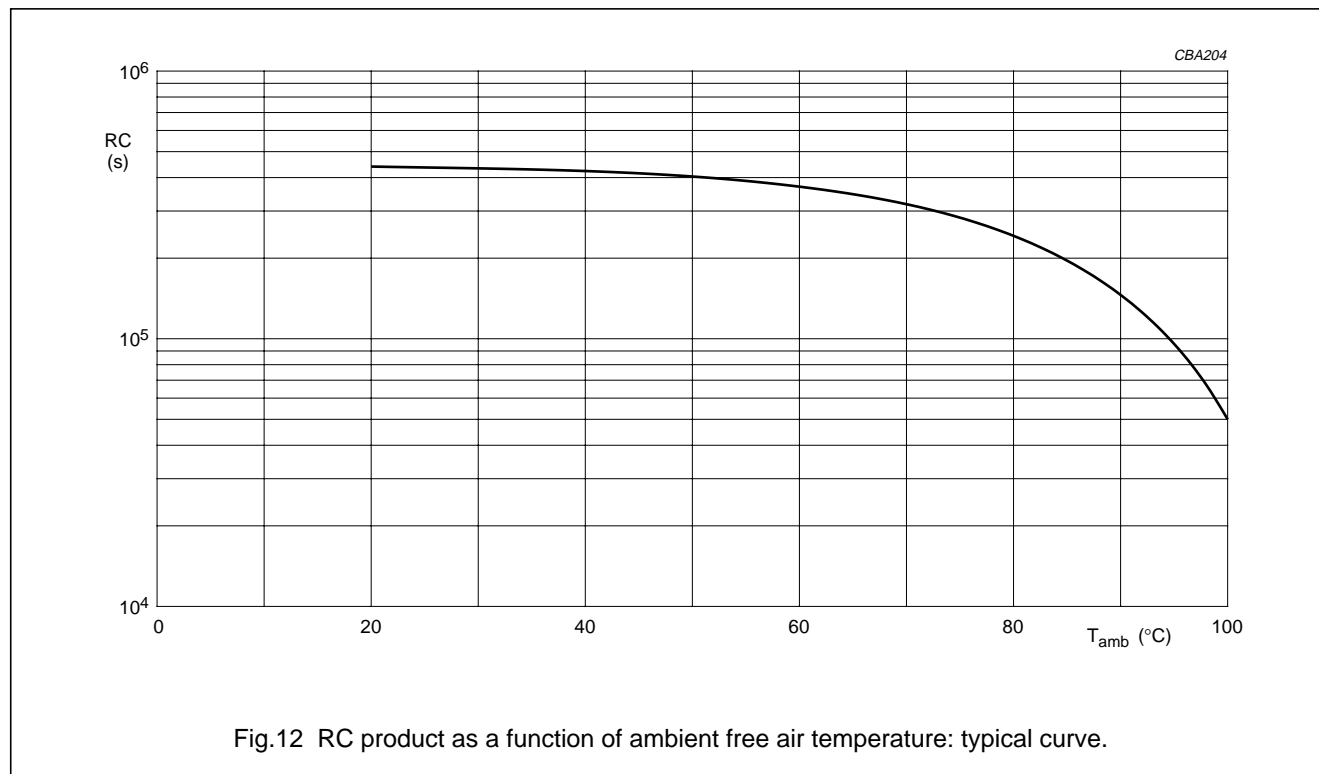

Fig.12 RC product as a function of ambient free air temperature: typical curve.

APPLICATION NOTES

- For X2 electromagnetic interference suppression in across the line applications (50 to 60 Hz) with a maximum mains voltage of 275 V (AC).
- These capacitors are not intended for continuous pulse applications. For these situations, capacitors of the AC and pulse program must be used, such as: 2222 375; 2222 383 or 2222 479
- The maximum ambient temperature must not exceed 100 °C.
- Rated voltage pulse slope:
 - If the pulse voltage is lower than the rated voltage, the values of the specific reference data can be multiplied by 385 V (DC) and divided by the applied voltage.

Interference suppression film capacitors

MKP 335 5

MARKING

Product marking

The capacitors are marked by laser print; on the top for pitch ≥ 22.5 mm (see Fig.14) or on the top and one side pitch ≤ 15 mm (see Fig.13) with the following information:

1. Rated capacitance code in accordance with "IEC 60062"
2. Tolerance on rated capacitance; M = $\pm 20\%$; K = $\pm 10\%$; J = $\pm 5\%$
3. Rated (AC) voltage (275 V)
4. Sub-class (e.g. X2)
5. Manufacturer's type designation (e.g. 335 5)
6. Code for dielectric material (MKP)
7. Manufacturer
8. Year and week of manufacture (e.g. 9840)
9. Safety approvals: products will be marked with approvals depending on the available marking space per product. Although all approvals remain valid as indicated in the reference data.

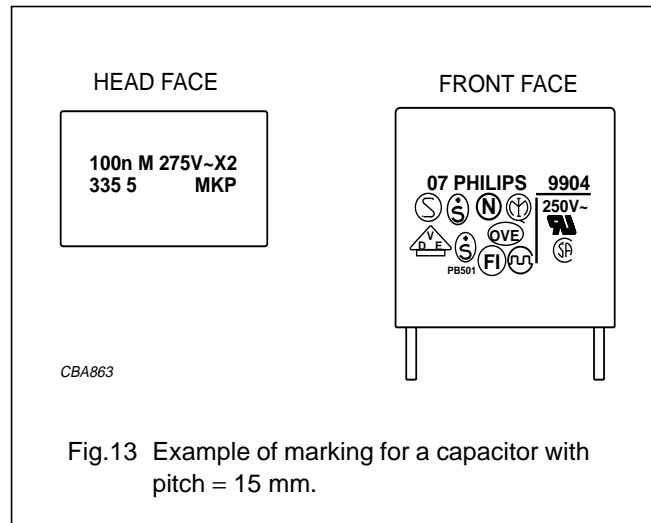

Fig.13 Example of marking for a capacitor with pitch = 15 mm.

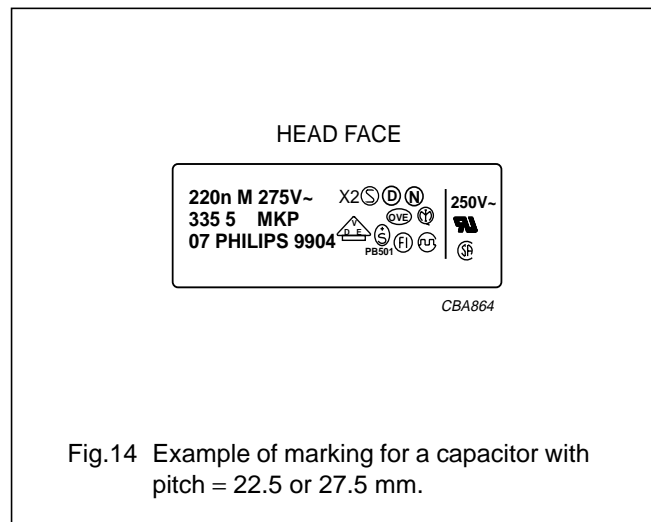

Fig.14 Example of marking for a capacitor with pitch = 22.5 or 27.5 mm.





Interference suppression film capacitors

MKP 335 5

Package marking

The package containing the capacitors is marked as shown Fig.15.

Please note:
In due time BC COMPONENTS
will replace PHILIPS COMPONENTS

1.	PHILIPS COMPONENTS		Barcode label marking
2.	MADE IN CHINA		LINE MARKING EXPLANATION
3.	INTERF. SUPPR. FILM CAPACITOR		1 Manufacturer's name
4.	MKP RADIAL POTTED TYPE X2		2 Country of origin
5.	0.1 μ F \pm 20% 275V \sim 55/100/56/B		3 Sub-family
			4 Type description and sub class
6.	BATCHNO E181201-02		5 Capacitance value, tolerance, voltage and climatic category ("IEC 60068-1")
			6 Batch number
7.	ORIG N260 RPC 07		7 Preference origin code: N Country of origin in code: 260 (China) Responsible production centre: 07
			8 Product type description
8.	TYPE MKP 335 5		9 Quantity and production period, year and week code
			10 Product code (12NC)
9.	QTY 750 DATE 9904		
			
10.	CODEND 2222 335 50104		

CCB843

Fig.15 Barcode label.

Interference suppression film capacitors

MKP 335 5

QUICK REFERENCE TEST REQUIREMENTS (see note 1)

TEST	PROCEDURE (quick reference)	REQUIREMENTS
Robustness of leads		
Tensile strength: "IEC 60068-2-21"	load 10 N; 10 s	no visible damage legible marking $ \Delta C/C \leq 5\%$ $\Delta \tan \delta \leq 80 \times 10^{-4}$ ($C \leq 1 \mu\text{F}$); note 2 $\Delta \tan \delta \leq 50 \times 10^{-4}$ ($C > 1 \mu\text{F}$); note 2
Bending: "IEC 60068-2-21"	load 5 N; $4 \times 90^\circ$	
Resistance to soldering heat: "IEC 60068-2-20"	solder bath: 260 °C; 10 s	
Component solvent resistance	isopropyl alcohol; 23 °C; 5 minutes	
Robustness of component		
Rapid change of temperature: "IEC 60068-2-14"	5 cycles 1 cycle = 30 minutes at -55 °C and 30 minutes at 100 °C	$ \Delta C/C \leq 5\%$ $\Delta \tan \delta \leq 80 \times 10^{-4}$ ($C \leq 1 \mu\text{F}$); note 2 $\Delta \tan \delta \leq 50 \times 10^{-4}$ ($C > 1 \mu\text{F}$); note 2
Vibration: "IEC 60068-2-6"	10 to 55 Hz; amplitude 0.75 mm; 6 hours	
Shock: "IEC 60068-2-27"	half sinewave; 490 m/s ² ; 11 ms	
Climatic sequence		
Dry heat: "IEC 60068-2-2"	16 hours; 100 °C	$ \Delta C/C \leq 5\%$ $\Delta \tan \delta \leq 80 \times 10^{-4}$ ($C \leq 1 \mu\text{F}$); note 2 $\Delta \tan \delta \leq 50 \times 10^{-4}$ ($C > 1 \mu\text{F}$); note 2 $R_{\text{ins}} \geq 50\%$ of specified value
Damp heat, cyclic, test Db, first cycle: "IEC 60068-2-30"		
Cold: "IEC 60068-2-1"	2 hours; -55 °C	
Damp heat, cyclic, test Db, remaining cycles: "IEC 60068-2-30"		
Voltage proof: "IEC 60384-14"	$V_p = 1200 \text{ V (DC)}$; 1 minute	
Other applicable tests		
Damp heat, steady state: "IEC 60068-2-3"	56 days; 40 °C; 90 to 95% RH $V_p = 1200 \text{ V (DC)}$; 1 minute	$ \Delta C/C \leq 5\%$ $\Delta \tan \delta \leq 80 \times 10^{-4}$ ($C \leq 1 \mu\text{F}$); note 2 $\Delta \tan \delta \leq 50 \times 10^{-4}$ ($C > 1 \mu\text{F}$); note 2 $R_{\text{ins}} \geq 50\%$ of specified value
Endurance (AC): "IEC 60384-14"	$3 \times 2.5 \text{ kV}$ pulse voltage for X2 1000 hours; $1.25 \times U_{\text{Rac}}$ at 100 °C; once per hour; 0.1 s; 1000 V (RMS) via resistor of 47 Ω ; $V_p = 1200 \text{ V (DC)}$; 1 minute	

Interference suppression film capacitors

MKP 335 5

TEST	PROCEDURE (quick reference)	REQUIREMENTS
Charge and discharge: "IEC 60384-14"	10000 cycles; 5 ms; $1.5 \times dV/dt$	$ \Delta C/C \leq 10\%$ $\Delta \tan \delta \leq 80 \times 10^{-4}$ ($C \leq 1 \mu F$); note 2 $\Delta \tan \delta \leq 50 \times 10^{-4}$ ($C > 1 \mu F$); note 2 $R_{ins} \geq 50\%$ of specified value
Passive flammability: "IEC 60384-14"	class B	no burning
Active flammability: "IEC 60384-14"	20×2.5 kV discharge for X2	no burning
Heat storage: "IEC 60384-14"	1000 hours; 100 °C	$ \Delta C/C \leq 5\%$ $\Delta \tan \delta \leq 80 \times 10^{-4}$ ($C \leq 1 \mu F$); note 2 $\Delta \tan \delta \leq 50 \times 10^{-4}$ ($C > 1 \mu F$); note 2
Resistance to soldering heat with preheating: "IEC 60384-14"	preheating: 100 °C; solder bath: 260 °C; 10 s	$ \Delta C/C \leq 5\%$ $\Delta \tan \delta \leq 80 \times 10^{-4}$ ($C \leq 1 \mu F$); note 2 $\Delta \tan \delta \leq 50 \times 10^{-4}$ ($C > 1 \mu F$); note 2
Active flammability test	voltage proof up to 4 kV (DC) or until breakdown (100 V/s, current limited 2mA) failed capacitors connected to a 250 V (AC) power supply during 5 minutes	no burning

Notes

1. For detailed information: see "Tentative detail specification HQX-48-300-188".
2. Measuring frequency 10 kHz for $C \leq 1 \mu F$ and 1 kHz for $C > 1 \mu F$.