

Description

Miniaturised single pole thermal circuit breaker with push-to-reset tease free, trip-free, snap action mechanism (R-type TO CBE to EN 60934). Available in versions for PCB or panel mounting, snap-in or threadneck, or as an integral type. Manual release facility optional for type 105. Approved to CBE standard EN 60934 (IEC 60934). For higher current ratings see type 1140.

Typical applications

Motors, transformers, solenoids, printed circuit boards, hand-held machines and appliances, marine applications, caravans.

Ordering information

Type No.	Description
104	PCB mounting type (-PR), or integral type (-P30/P10)
105	snap-in panel mounting
106	threadneck panel mounting with hex and knurled nut *
106-M2	threadneck panel mounting 3/8-27UNS with collar, hex nut and knurled nut*
Terminal design	
P10	blade terminals A6.3-0.8 (QC .250)
P30	blade terminals A2.8-0.8 (QC .110)
PR	solder terminal pins for PCB mounting (type 104 only)
PR2	PCB mounting (vertical), type 104 only up to 6 A
PR3	PCB mounting (vertical), type 104 only
Shunt terminal (optional)	
A3	same as main terminals (up to I_N 6 A/3 A max. load)
Manual release facility (optional)	
H	only with type 105
Auxiliary contacts (optional)	
Si51	type 104 only
Current ratings	
0.05...10 A	

106 - P30 - .. - .. - .. - 5 A = ordering example

The exact part number required can be built up from the table of choices shown above. Ordering references for optional features should be omitted if not required.

* mounting hardware bulk shipped

Standard current ratings and typical internal resistance values

Current rating (A)	Internal resistance (Ω)	Current rating (A)	Internal resistance (Ω)
0.05	285	1.8	0.28
0.08	134	2	0.25
0.1	81	2.5	0.18
0.2	22	3	0.11
0.3	8.7	3.5	0.076
0.4	5.5	4	0.067
0.5	3.3	4.5	0.051
0.6	2.45	5	≤ 0.05
0.7	1.6	6	≤ 0.05
0.8	1.45	7	≤ 0.05
1	0.9	8	≤ 0.05
1.2	0.6	10	≤ 0.05
1.5	0.4		

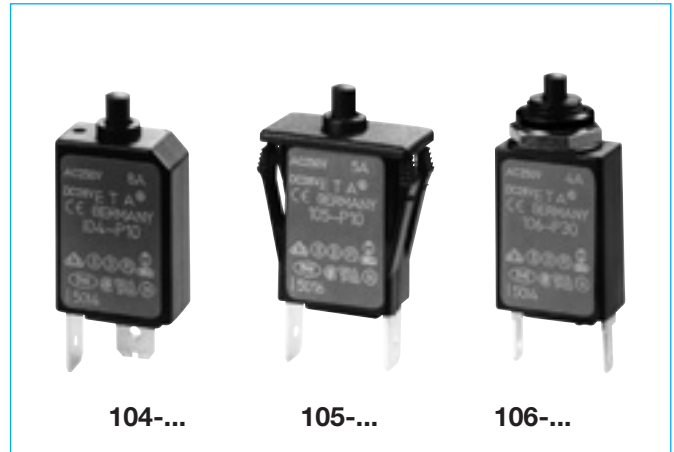

Technical data

For further details please see chapter: Technical Information

Voltage rating	AC 240 V; DC 48 V (UL: AC 250 V; DC 48 V)		
Current ratings	0.05...10 A		
Auxiliary circuit	0.5 A, AC 240 V, DC 28 V		
Typical life			
AC 240 V	0.05...8 A	2,000 operations at $1 \times I_N$, inductive	
	0.05...5 A	3,000 operations at $2 \times I_N$, inductive	
	6...8 A:	500 operations at $2 \times I_N$, inductive	
DC 48 V	0.05...8 A	2,000 operations at $1 \times I_N$, inductive	
	0.05...5 A	3,000 operations at $2 \times I_N$, inductive	
	6...8 A:	500 operations at $2 \times I_N$, inductive	
	10 A	200 operations at $1 \times I_N$, inductive	
	10 A	50 operations at $2 \times I_N$, inductive	
Ambient temperature	-20...+60 °C (-4...+140 °F) T 60		
Insulation co-ordination (IEC 60664 and 60664 A)	rated impulse withstand voltage	pollution degree	
	2.5 kV	2	
	reinforced insulation in operating area		
Dielectric strength (IEC 60664 and 60664A)	test voltage		
operating area	AC 3,000 V		
Insulation resistance	> 100 M Ω (DC 500 V)		
Interrupting capacity I_{cn}	0.05...8 A	6 x I_N AC	
	> 8...10 A	5 x I_N AC	
	0.05...10 A	6 x I_N DC	
Interrupting capacity (UL 1077)	I_N	U_N	
	0.05...10 A	AC 250 V	2,000 A
	0.05...10 A	DC 48 V	200 A
Degree of protection (IEC 60529/DIN 40050)	operating area IP40 terminal area IP00		
Vibration	10 g (57-500 Hz), ± 0.76 mm (10-57 Hz), to IEC 60068-2-6, test Fc, 10 frequency cycles/axis		
Shock	25 g (11 ms) to IEC 60068-2-27, test Ea		
Corrosion	96 hours at 5 % salt mist, to IEC 60068-2-11, test Ka		
Humidity	240 hours at 95 % RH, to IEC 60068-2-3, test Ca		
Mass	approx. 10 g		

Approvals

Authority	Voltage ratings	Current ratings
VDE, SEV,	AC 240 V	0.05...8 A
Kema (EN 60934)	DC 48 V	0.05...10 A
CSA, UL	AC 250 V; DC 48 V	0.05...10 A

Circuit breakers with -Si51 not approved

Dimensions

104-P30

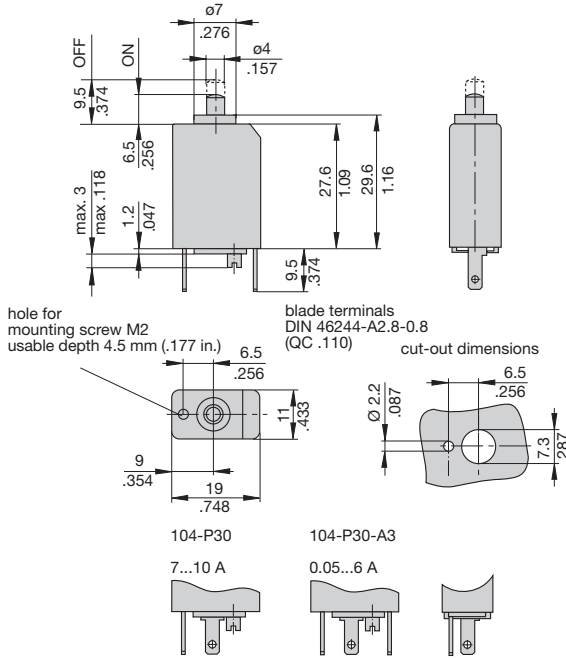

104-PR-(A3)-Si51

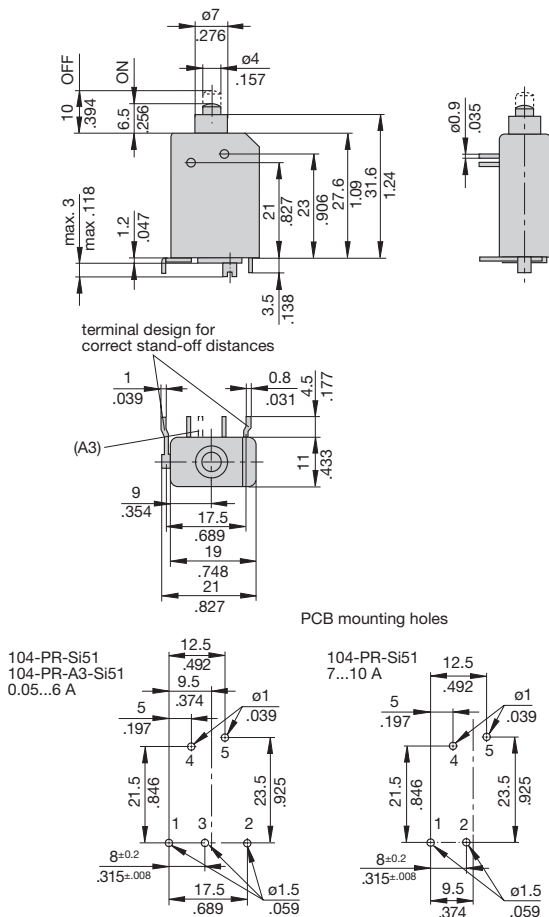

104-PR

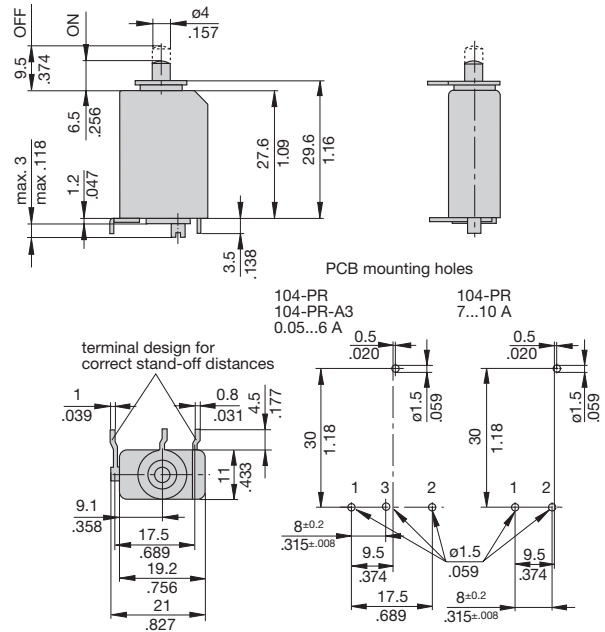

104-PR3

0.05...6 A

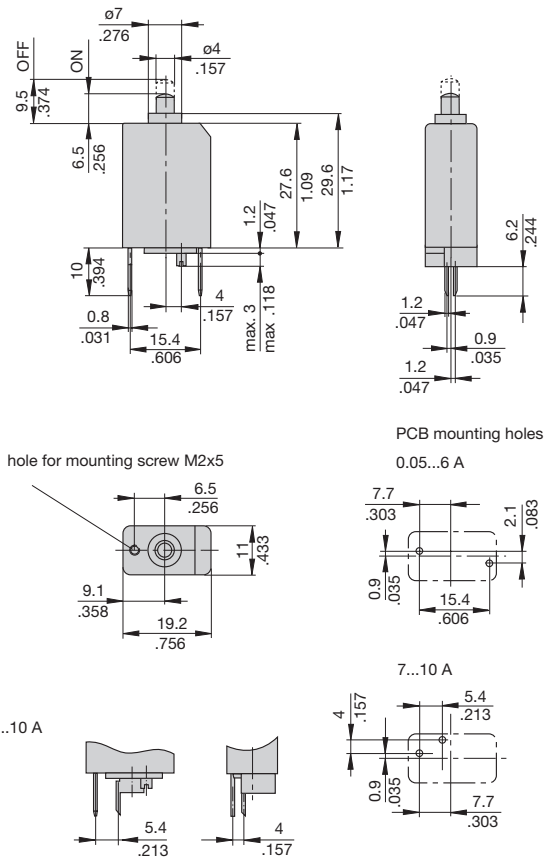

This is a metric design and millimeter dimensions take precedence (mm/inch)

Dimensions

104-PR2

0.05...6 A

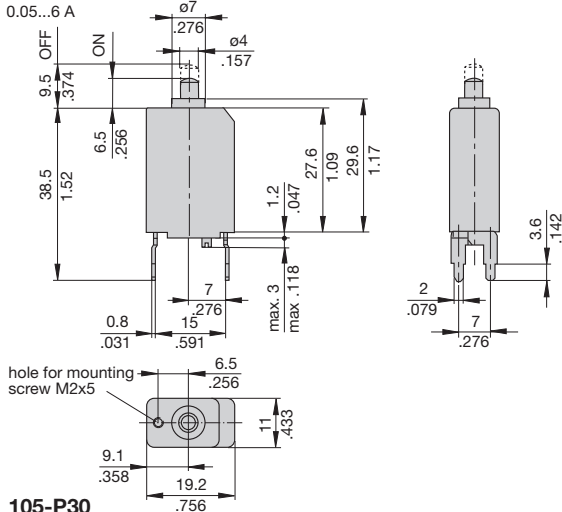

105-P30

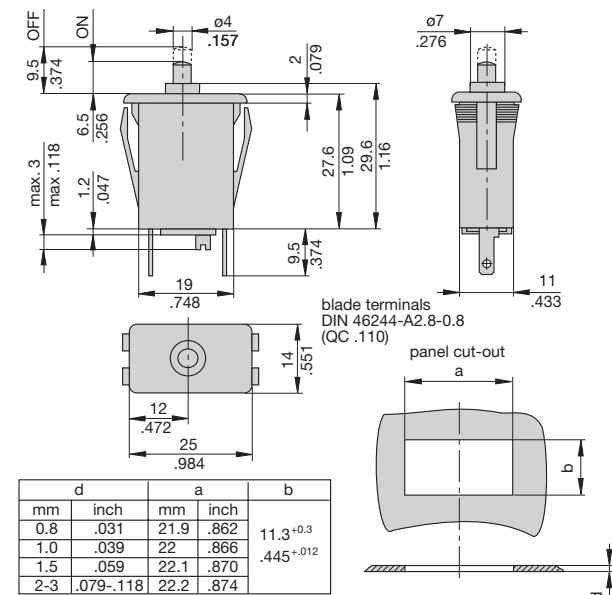

105-P307...10 A

105-P30-A3
0.05...6 A

105-P..-H

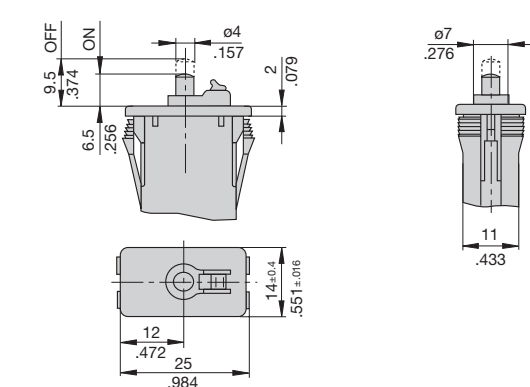

106-P30

$\frac{3}{8}$ -27UNS-2A
tightening torque max. 0.8 Nm

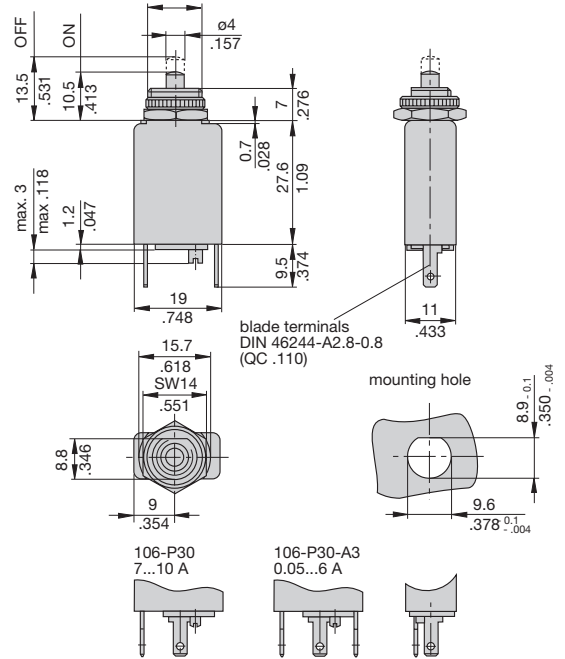

106-M2

$\frac{3}{8}$ -27UNS-2A
tightening torque max. 0.8 Nm

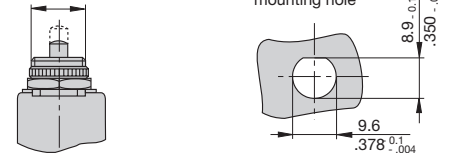

Terminal design

104/105/106-P10

0.05...6 A

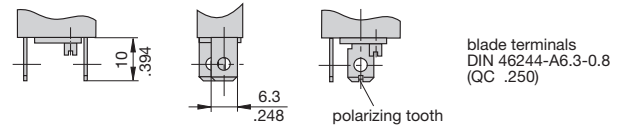

104/105/106-P10-A3

0.05...6 A

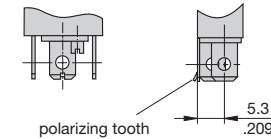

104/105/106-P30-A3

0.05...6 A

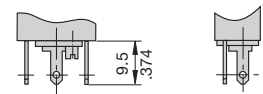

This is a metric design and millimeter dimensions take precedence ($\frac{mm}{inch}$)

Installation drawings

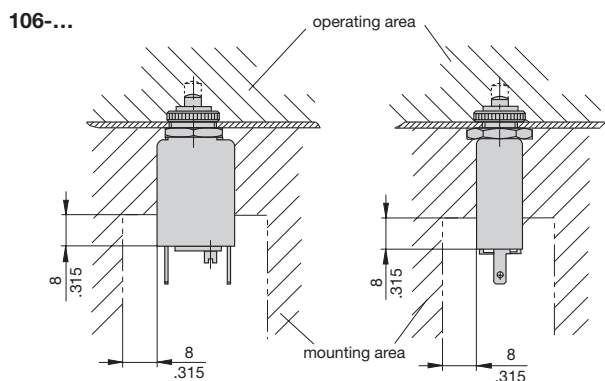
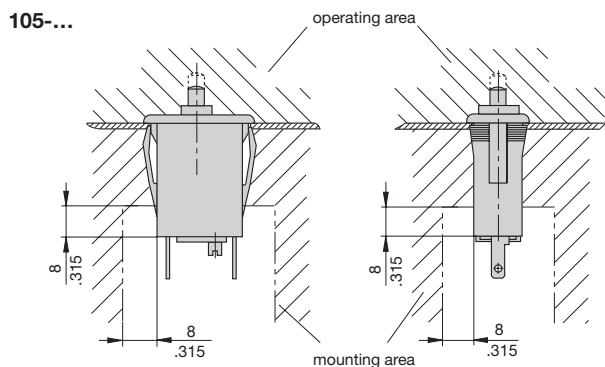
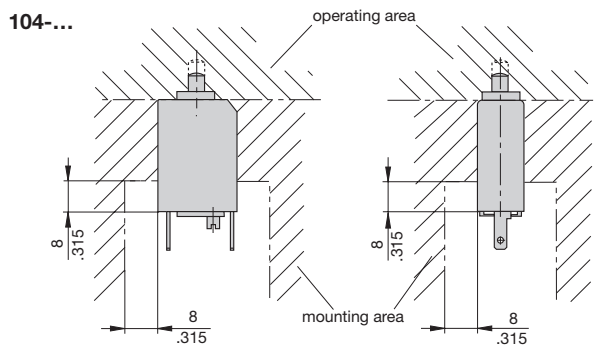

Internal connection diagrams

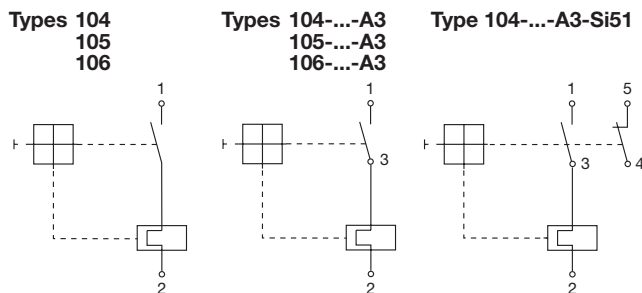

Typical time/current characteristics at +23°C/+73.4°F

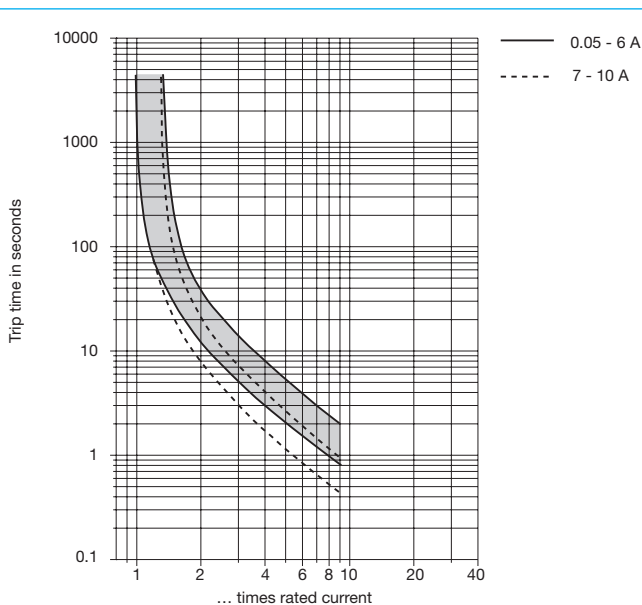

The time/current characteristic curve depends on the ambient temperature prevailing. In order to eliminate nuisance tripping, please multiply the circuit breaker current ratings by the derating factor shown below. See also section 9 – Technical information.

Ambient temperature °F	-4	+14	+32	+73.4	+104	+122	+140
°C	-20	-10	0	+23	+40	+50	+60
Derating factor	0.76	0.84	0.92	1	1.08	1.16	1.24

Accessories

Water splash cover (transparent)/knurled nut assembly
(type 106-... only)
X 201 285 01
Degree of protection IP 64

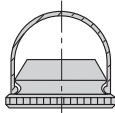

This is a metric design and millimeter dimensions take precedence $\left(\frac{\text{mm}}{\text{inch}}\right)$

All dimensions without tolerances are for reference only. In the interest of improved design, performance and cost effectiveness the right to make changes in these specifications without notice is reserved. Product markings may not be exactly as the ordering codes. Errors and omissions excepted.

Description

Single pole toggle switch/thermal circuit breakers (S-type TO CBE to EN 60934) for threadneck panel mounting. Available with optional neon illumination (filament bulb for low voltages) to indicate the ON position. Fitted with toggle or baton style actuator in a range of colours - translucent for illuminated version. Under overload the actuator returns to the OFF position.

For two or three pole protection see types 3120 and 3130.

Typical applications

Motors, transformers, solenoids, extra-low voltage wiring systems, power supplies.

Ordering information

Type No.	
110	non illuminated
111	illuminated (please specify voltage)
Terminal design	
P10	blade terminals A6.3-0.8 (QC .250)
Shunt terminal (optional)	
A3	shunt terminal, max. load 5 A
Mounting	
G10	threadneck panel mounting, 1/2-32UN-2A*
Switch style options	
OB	baton
WB	baton - water splash protected (IP54)
OT	toggle
WT	toggle - water splash protected (IP54)
Switch colour designation	
	opaque translucent for type 111
01	black 14 red
02	white 15 orange
04	red 17 transparent
06	blue
08	grey
09	green
Current ratings	
0.1...20 A (type 110)	
0.1...16 A (type 111)	
Illumination (type 111 only)	
12 V DC	10 to 14 V
24 V DC	20 to 28 V
115 V AC	90 to 140 V
220 V AC	185 to 275 V

111 - P10 - .. - G10 - OB 14 - 5 A - 12 V = ordering example

The exact part number required can be built up from the table of choices shown above. Ordering references for optional features should be omitted if not required.

*mounting hardware bulk shipped

Standard current ratings and typical internal resistance values

Current rating (A)	Internal resistance (Ω)	Current rating (A)	Internal resistance (Ω)	Current rating (A)	Internal resistance (Ω)
0.1	97.6	1.2	0.66	6	0.03
0.2	22.4	1.5	0.50	8	< 0.02
0.3	10.9	1.8	0.33	10	< 0.02
0.4	6.1	2	0.27	12	< 0.02
0.5	4.0	2.5	0.2	15	< 0.02
0.6	2.7	3	0.1	16	< 0.02
0.7	1.8	3.5	0.09	18	< 0.02
0.8	1.6	4	0.05	20	< 0.02
1	1.07	5	0.04		



110-P10-G10
111-P10-G10 (illuminated)

Technical data

Voltage rating	AC 250 V; DC 28 V		
Current ratings	0.1...20 A (type 110) 0.1...16 A (type 111)		
Typical life	30,000 operations at 1 x I _N or 5,000 operations at 2 x I _N		
Ambient temperature	-30...+60 °C (-22...+140 °F)		
Insulation co-ordination (IEC 60664 and 60664 A)	rated impulse withstand voltage 2.5 kV	pollution degree 2	reinforced insulation in operating area
Dielectric strength (IEC 60664 and 60664 A) operating area	test voltage AC 3,000 V		
Insulation resistance	> 100 MΩ (DC 500 V)		
Interrupting capacity I _{cn}	10 x I _N		
Interrupting capacity (UL 1077)	I _N 0.1...16 A 18...20 A	U _N AC 250 V AC 125 V	2,000 A 2,000 A
Degree of protection (IEC 60529/DIN 40 050)	operating area IP40 terminal area IP00		
Vibration	4 g (57-500 Hz) ±0.3 mm (10-57 Hz), to IEC 60068-2-6, test Fc, 10 frequency cycles/axis		
Shock	30 g (11 ms), to IEC 60068-2-27, test Ea		
Corrosion	48 hours at 5 % salt mist, to IEC 60068-2-11, test Ka		
Humidity	240 hours at 95 % RH to IEC 60068-2-3, test Ca		
Mass	approx. 30 g		

Approvals

Authority	Voltage ratings	Current ratings
CSA / UL	AC 250 V; DC 28 V AC 125 V; DC 28 V	0.1...16 A 18...20 A

Dimensions 110/111-P10-G10-...

110/111-P10(-A3)-G10-OB../-WB..

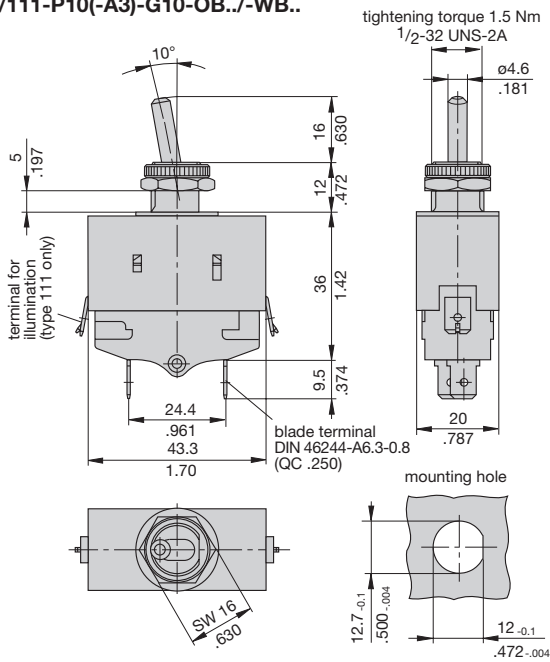

110/111-P10(-A3)-G10-OT../-WT..

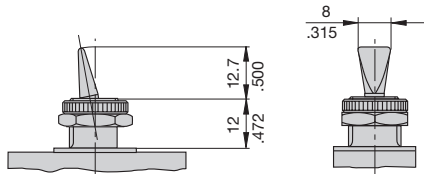

Typical time/current characteristics at +23°C/+73.4°F

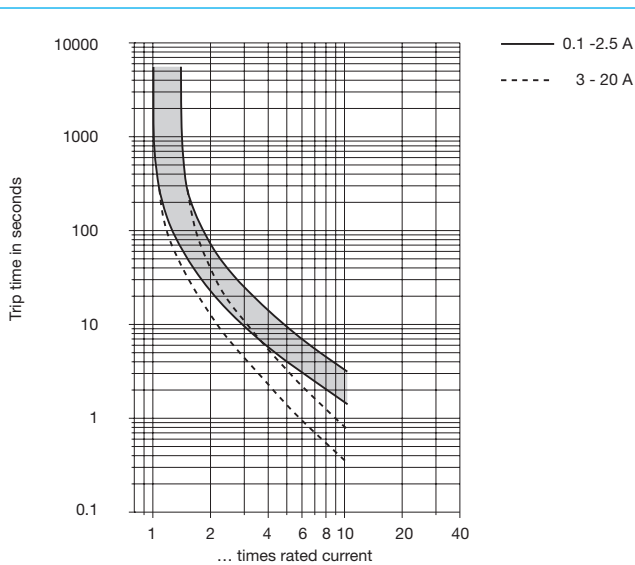

The time/current characteristic curve depends on the ambient temperature prevailing. In order to eliminate nuisance tripping, please multiply the circuit breaker current ratings by the derating factor shown below. See also section 9 – Technical information.

Ambient temperature °F	-22	-4	+14	+32	+73.4	+104	+122	+140
°C	-30	-20	-10	0	+23	+40	+50	+60
Derating factor	0.68	0.76	0.84	0.92	1	1.08	1.16	1.24

Installation drawings

110-P10-G10-OB../-WB../-OT../-WT..

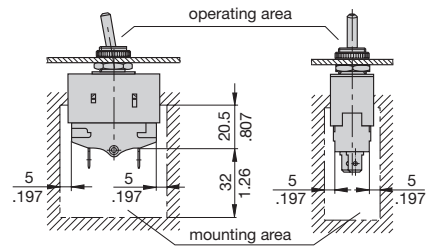

110-P10-A3-G10-OB../-WB../-OT../-WT..

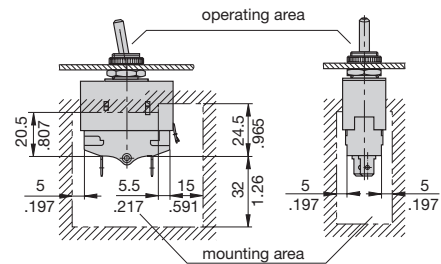

111-P10-G10-OB../-WB../-OT../-WT..

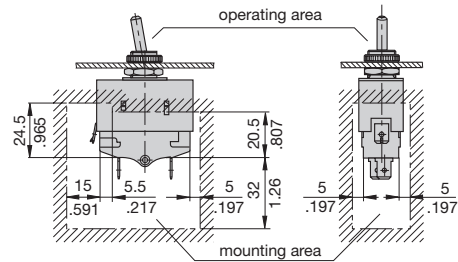

111-P10-A3-G10-OB../-WB../-OT../-WT..

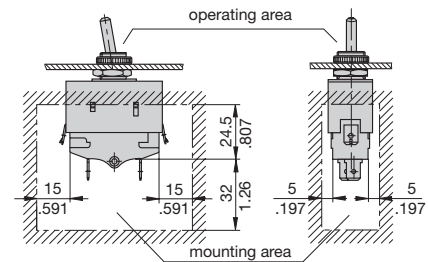

Internal connection diagrams

110-P10-...

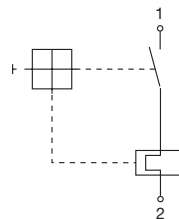

111-P10-...

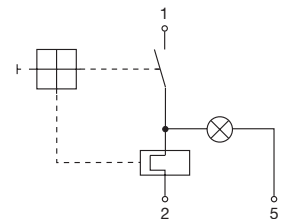

This is a metric design and millimeter dimensions take precedence ($\frac{\text{mm}}{\text{inch}}$)

All dimensions without tolerances are for reference only. In the interest of improved design, performance and cost effectiveness the right to make changes in these specifications without notice is reserved. Product markings may not be exactly as the ordering codes. Errors and omissions excepted.

Description

Single pole thermal circuit breaker with push-to-reset, tease-free, trip-free, snap action mechanism (R-type TO CBE to EN 60934; M-type when fitted with optional manual release feature). Available in versions for plug-in or integral mounting, track mounting, or with a frame for snap-in panel mounting. The optional -KF housing is particularly suited to high humidity and other damp conditions. Approved to CBE standard EN 60934 (IEC 60934).

Typical applications

Motors, transformers, solenoids, battery chargers, extra low voltage systems.

Ordering information

Type No.
127
Mounting options
leave blank for integral/plug-in option
F for snap-in mounting
T11 track mounting with captive stud terminals M4
T12 track mounting with screw terminals M4
Terminal design (for use with and without flange -F)
P10 blade terminals A6.3-0.8 (QC .250)
K10 screw terminals M4x6
Manual release (optional)
H manual release facility
Special housing (optional)
KF for tropical and high humidity conditions (not for -T11 and -T12)
Current ratings
0.05...25 A

127 - F - P10 - H - .. - 10 A = ordering example

The exact part number required can be built up from the table of choices shown above. Ordering references for optional features should be omitted if not required.

Standard current ratings and typical internal resistance values

Current rating (A)	Internal resistance (Ω)	Current rating (A)	Internal resistance (Ω)
0.05	280	1.5	0.6
0.08	100	1.8	0.4
0.1	110	2	0.3
0.15	56	2.5	0.2
0.2	29	3	0.1
0.25	18	3.5	0.06
0.3	14	4	0.06
0.35	9.8	4.5	0.05
0.4	7	5	0.05
0.45	5.9	6	0.02
0.5	4.9	7	0.02
0.6	3.4	8	0.02
0.7	2.5	10	< 0.02
0.8	1.8	15	< 0.02
0.9	1.5	16	< 0.02
1	1.2	20	< 0.02
1.2	0.8	25	< 0.02

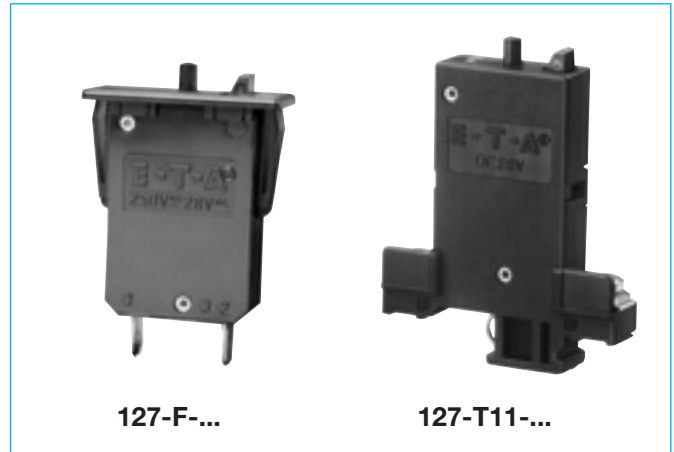

Technical data

For further details please see chapter: Technical Information

Voltage rating	AC 250 V; DC 28 V (UL: AC 250 V; DC 50 V)	
Current ratings	0.05...25 A	
Typical life	0.05...16 A	5,000 operations at 2 x I _N , inductive
	17...25 A	5,000 operations at 2 x I _N , resistive
Ambient temperature	-20...+60 °C (-4...+140 °F)	
Insulation co-ordination (IEC 60664 and 60664 A)	rated impulse withstand voltage 2.5 kV	pollution degree 2
	reinforced insulation in operating area	
Dielectric strength (IEC 60664 and 60664A)	test voltage operating area AC 3,000 V	
Insulation resistance	> 100 MΩ (DC 500 V)	
Interrupting capacity I _{cn}	type -F: 0.05 ...2.5 A	8 x I _N
	3...5 A	20 x I _N
	6...12 A	200 A
	13...25 A	400 A
	type -T: 0.05...2.5 A	8 x I _N
	3...5 A	20 x I _N
	6...25 A	400 A
Degree of protection (IEC 60529/DIN 40050)	operating area IP40 terminal area IP00	
Vibration	8 g (57-500 Hz) ±0.61 mm (10-57 Hz) to IEC 60068-2-6, test Fc, 10 frequency cycles/axis	
Shock	25 g (11 ms), to IEC 60068-2-27, test Ea	
Corrosion	96 hours at 5 % salt mist, to IEC 60068-2-11, test Ka	
Humidity	240 hours at 95 % RH to IEC 60068-2-3, test Db	
Mass	127-F-...: approx. 24 g 127-T-...: approx. 35 g	

Approvals

Authority	Voltage ratings	Current ratings
VDE (EN 60934)	AC 250 V; DC 28 V	0.05...25 A
CSA, UL	AC 250 V DC 50 V	0.1...20 A 0.1...25 A
CCC	AC 250 V	0.05...25 A
Type 127-T..- approvals N/A		

Dimensions

127-F-P10-H

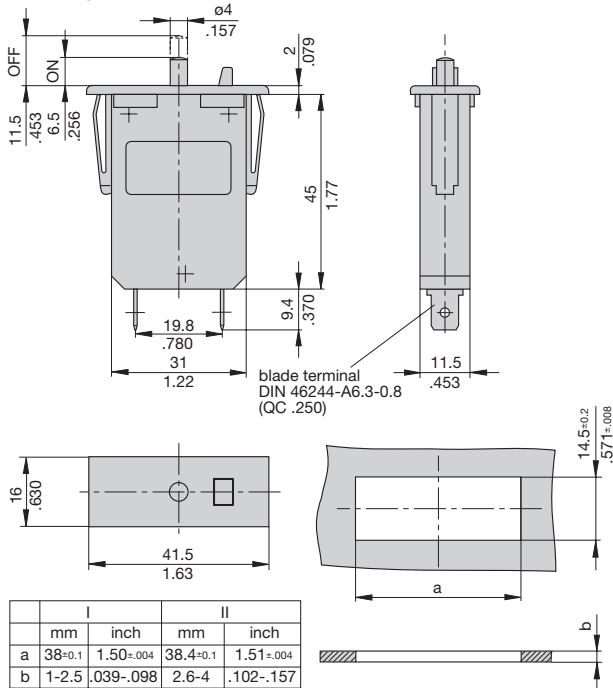

127-T11

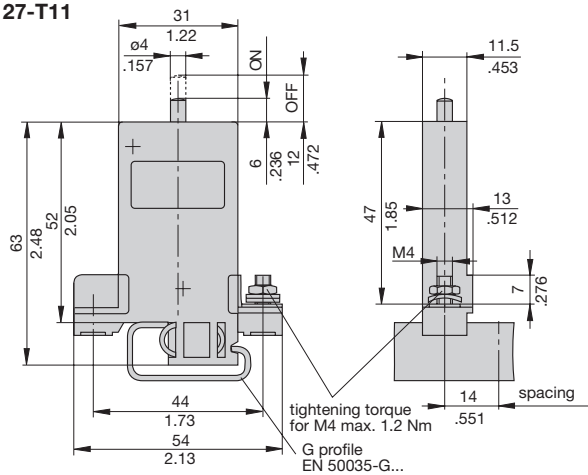

127-T12

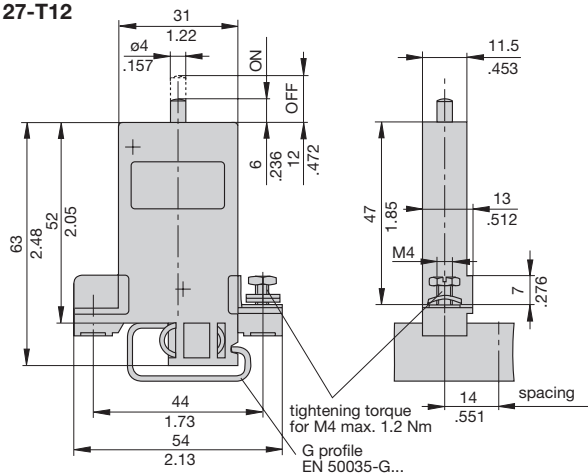

Installation drawings

127-F

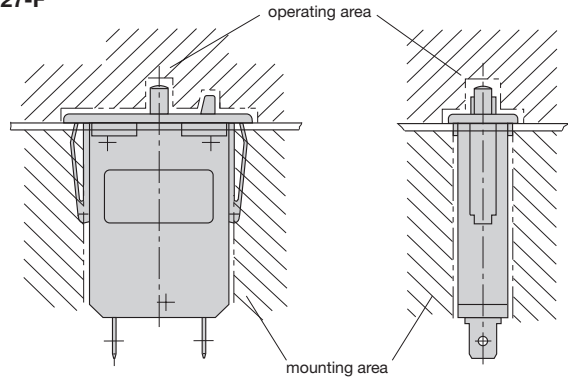

127-T11

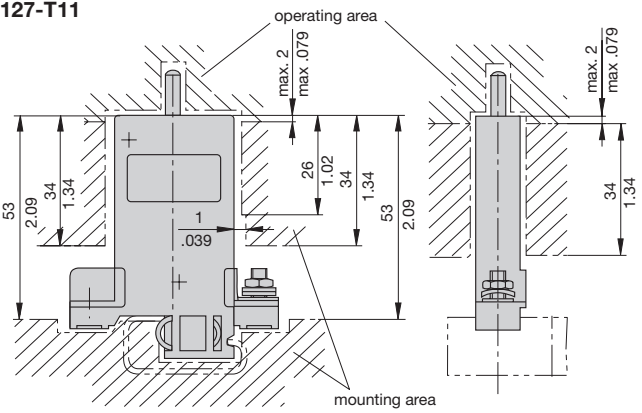

127-T12

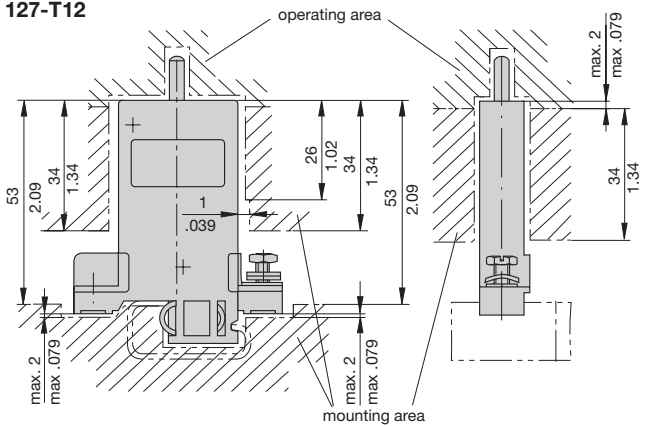

Terminal design 127-F-K10

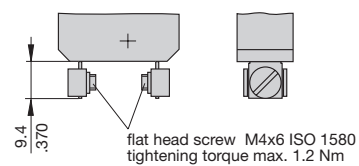

This is a metric design and millimeter dimensions take precedence (mm)
inch

Internal connection diagram

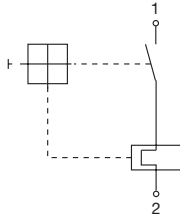

Typical time/current characteristics at +23°C/+73.4°F

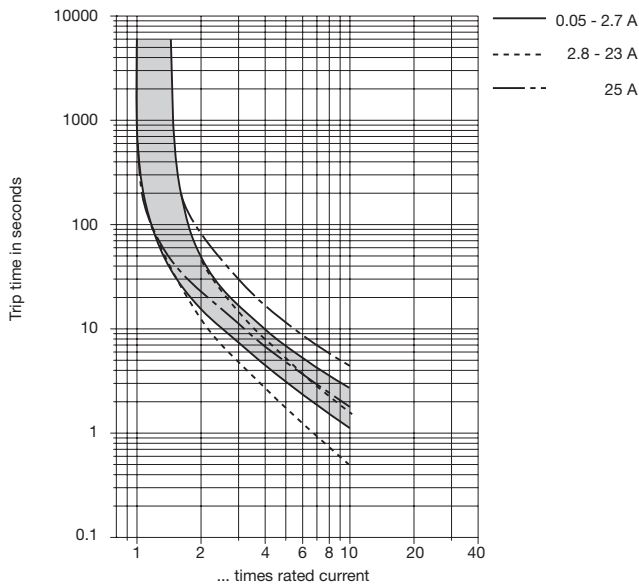

The time/current characteristic curve depends on the ambient temperature prevailing. In order to eliminate nuisance tripping, please multiply the circuit breaker current ratings by the derating factor shown below. See also section 9 – Technical information.

Ambient temperature °F	-4	+14	+32	+73.4	+104	+122	+140
°C	-20	-10	0	+23	+40	+50	+60
Derating factor	0.76	0.84	0.92	1	1.08	1.16	1.24

Accessories

Mounting sockets

10F-P10 (up to 16 A max. load)

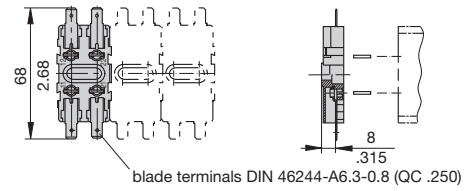

10F-K10 (up to 20 A max. load)

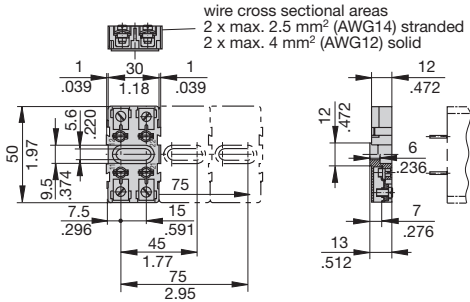

10F-A10 (up to 16 A max. load)

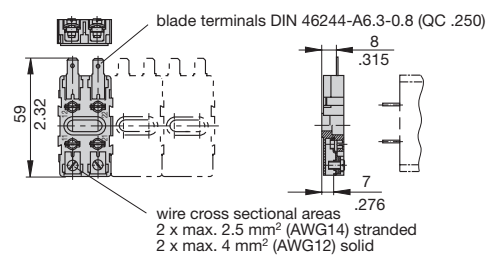

Accessories for sockets (up to 20 A max. load)

2-way bus bar **Y 301 166 02**

4-way bus bar **Y 301 166 01**

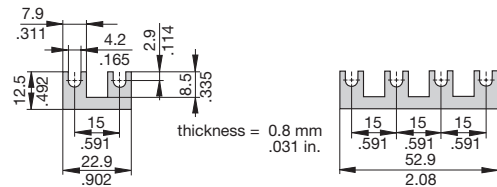

Connector bus links -K10

X 210 589 01/ 2.5 mm² (AWG 14), black (up to 20 A max. load)

X 210 589 02/ 1.5 mm² (AWG 16), brown (up to 13 A max. load)

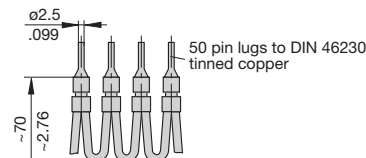

Connector bus links -P10

X 210 588 01/ 1.5 mm² (AWG 16), brown (up to 13 A max. load)

X 210 588 02/ 2.5 mm² (AWG 14), black (up to 20 A max. load)

X 210 588 03/ 2.5 mm² (AWG 14), red (up to 20 A max. load)

X 210 588 04/ 2.5 mm² (AWG 14), blue (up to 20 A max. load)

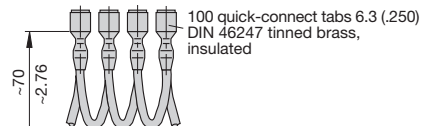

All dimensions without tolerances are for reference only. In the interest of improved design, performance and cost effectiveness the right to make changes in these specifications without notice is reserved. Product markings may not be exactly as the ordering codes. Errors and omissions excepted.

This is a metric design and millimeter dimensions take precedence (mm/inch)

Description

Single pole thermal circuit breaker with push-to-reset, tease-free, trip-free, snap action mechanism and separate manual release (M-type TO CBE to EN 60934). Designed for bolt-on mounting with terminal block type 83-P10.

Typical applications

Extra low voltage wiring systems on all types of vehicles and marine craft.

Ordering information

Type No.	
129	base mounting and connection
	Terminal design
L11	90 ° bent terminals
	Manual release
H	manual release facility
	Housing
KF	standard
	Current ratings
	3...25 A
129 - L11 - H - KF - 10 A = ordering example	

Standard current ratings and typical internal resistance values

Current rating (A)	Internal resistance (Ω)	Current rating (A)	Internal resistance (Ω)
3	0.1	8	0.02
3.5	0.06	10	< 0.02
4	0.06	12	< 0.02
4.5	0.05	16	< 0.02
5	0.05	20	< 0.02
6	0.02	25	< 0.02
7	0.02		

Approvals

Authority	Voltage rating	Current rating
CSA, UL	AC 250 V	3...20 A
	DC 50 V	3...25 A
BWB (VG 95345 part 9)	DC 28 V	6...25 A



129-L11-H-KF

Technical data

Voltage rating	DC 28 V (UL: AC 250 V; DC 50 V)	
Current ratings	3...25 A	
Typical life	5,000 operations at $2 \times I_N$	
Ambient temperature	-40...+75 °C (-40...167 °F)	
Insulation co-ordination (IEC 60664 and 60664 A)	rated impulse withstand voltage 2.5 kV	pollution degree 2
Dielectric strength (IEC 60664 and 60664A) operating area	test voltage AC 1,500 V	
Insulation resistance	> 100 MΩ (DC 500 V)	
Interrupting capacity I_{cn}	3...5 A $20 \times I_N$ 6...25 A 400 A	
Degree of protection (IEC 60529/DIN 40050)	operating area IP32 terminal area IP00	
Vibration	10 g (55-2000 Hz), ±0.76 mm (10-55 Hz) to VG 95210 part 28	
Shock	50 g (11 ms) to VG 95210 part 28	
Corrosion	96 hours at 5 % salt mist, to VG 95210 part 2	
Humidity	240 hours at 95 % RH to VG 95210 part 7	
Mass	approx. 25 g	

Dimensions

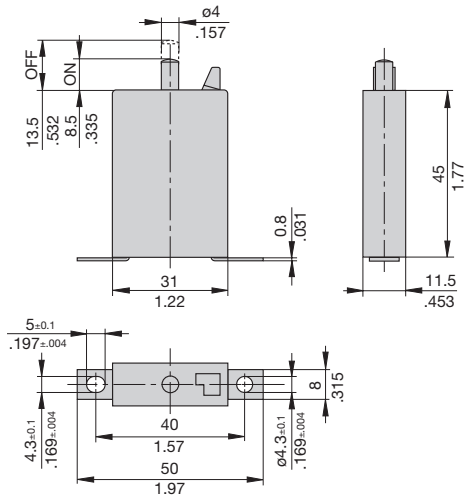

Internal connection diagram

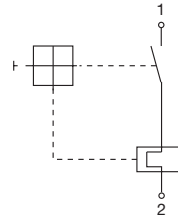

Typical time/current characteristics at +23°C/+73.4°F

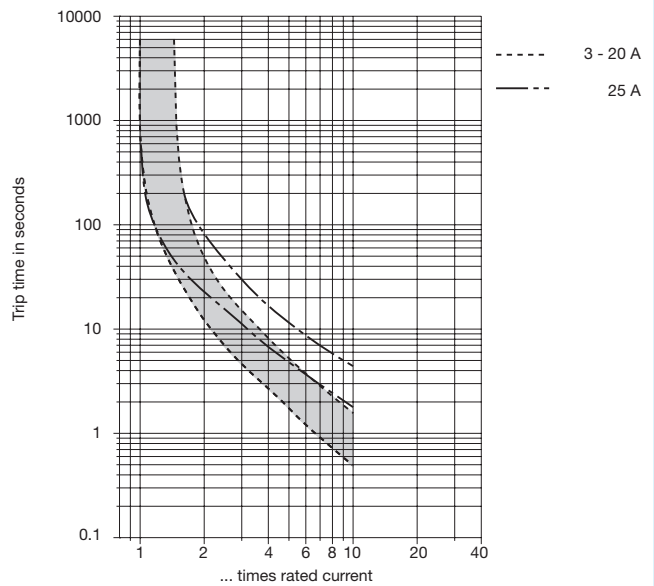

The time/current characteristic curve depends on the ambient temperature prevailing. In order to eliminate nuisance tripping, please multiply the circuit breaker current ratings by the derating factor shown below. See also section 9 – Technical information.

Ambient temp. °F	-40	-4	+14	+32	+73.4	+104	+122	+140	+167
°C	-40	-20	-10	0	+23	+40	+50	+60	+75
Derating factor	0,60	0,76	0,84	0,92	1	1,08	1,16	1,24	1,35

Accessories

Mounting block 83-P10

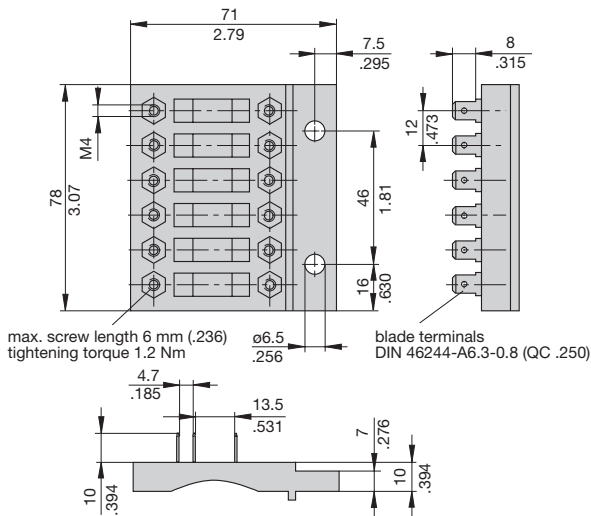

This is a metric design and millimeter dimensions take precedence ($\frac{mm}{inch}$)

All dimensions without tolerances are for reference only. In the interest of improved design, performance and cost effectiveness the right to make changes in these specifications without notice is reserved. Product markings may not be exactly as the ordering codes. Errors and omissions excepted.

Description

Single pole thermal circuit breaker with push-to-reset, tease-free, trip-free, snap action mechanism (R-type TO CBE to EN 60934). Available in versions for threadneck panel mounting, plug-in or integral mounting. The optional -KF housing is particularly suited to high humidity and other damp conditions. Approved to CBE standard EN 60934 (IEC 60934).

Typical applications

Motors, transformers, solenoids, extra low voltage wiring systems.

Ordering information

Type No.	
157	threadneck panel mounting*
158	integral or plug-in mounting
Terminal design	
P10	blade terminals A6.3-0.8 (QC .250)
K10	screw terminals M4x6
Special housing (optional)	
KF	for tropical and high humidity conditions
Current ratings	
0.05...25 A	
157 - P10 - .. - 10 A = ordering example	

The exact part number required can be built up from the table of choices shown above. Ordering references for optional features should be omitted if not required.

*mounting hardware bulk shipped

Standard current ratings and typical internal resistance values

Current rating (A)	Internal resistance (Ω)	Current rating (A)	Internal resistance (Ω)
0.05	280	3	0.1
0.08	100	3.5	0.06
0.1	110	4	0.06
0.2	29	4.5	0.05
0.3	14	5	0.05
0.4	7	6	0.02
0.5	4.9	7	0.02
0.6	3.4	8	0.02
0.7	2.5	10	< 0.02
0.8	1.8	12	< 0.02
1	1.2	13	< 0.02
1.2	0.8	15	< 0.02
1.5	0.6	16	< 0.02
1.8	0.2	20	< 0.02
2	0.3	22	< 0.02
2.5	0.2	25	< 0.02

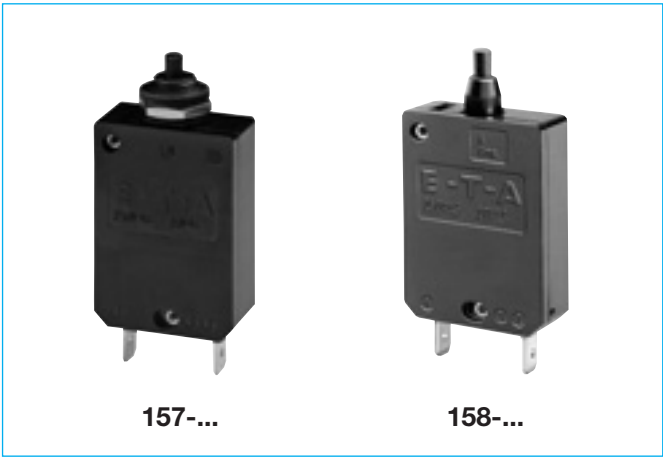

Technical data

For further details please see chapter: Technical Information

Voltage rating	AC 250 V; DC 28 V (UL: AC 250 V; DC 50 V)	
Current ratings	0.05...25 A	
Typical life	0.05...16 A	5,000 operations at 2 x I _N , inductive
	17...25 A	5,000 operations at 2 x I _N , resistive
Ambient temperature	-20...+60 °C (-4...+140 °F)	
Insulation co-ordination (IEC 60664 and 60664 A)	rated impulse withstand voltage 2.5 kV	pollution degree 2
	reinforced insulation in operating area	
Dielectric strength (IEC 60664 and 60664A)	test voltage operating area	AC 3,000 V
Insulation resistance	> 100 MΩ (DC 500 V)	
Interrupting capacity I _{cn}	0.05...2.5 A	8 x I _N
	3...5 A	20 x I _N
	6...12 A	200 A
	13...25 A	400 A
Degree of protection (IEC 60529/DIN 40050)	operating area IP40 terminal area IP00	
Vibration	8 g (57-500 Hz) ±0.61 mm (10-57 Hz) to IEC 60068-2-6, test Fc, 10 frequency cycles/axis	
Shock	25 g (11 ms) to IEC 60068-2-27, test Ea	
Corrosion	96 hours at 5 % salt mist, to IEC 60068-2-11, test Ka	
Humidity	240 hours at 95 % RH to IEC 60068-2-3, test Ca	
Mass	approx. 24 g	

Approvals

Authority	Voltage ratings	Current ratings
VDE (EN 60934)	AC 250 V; DC 28 V	0.05...25 A
CSA, UL	AC 250 V	0.1...16 A
CCC	AC 250 V	0.05...25 A

Dimensions

157-P10

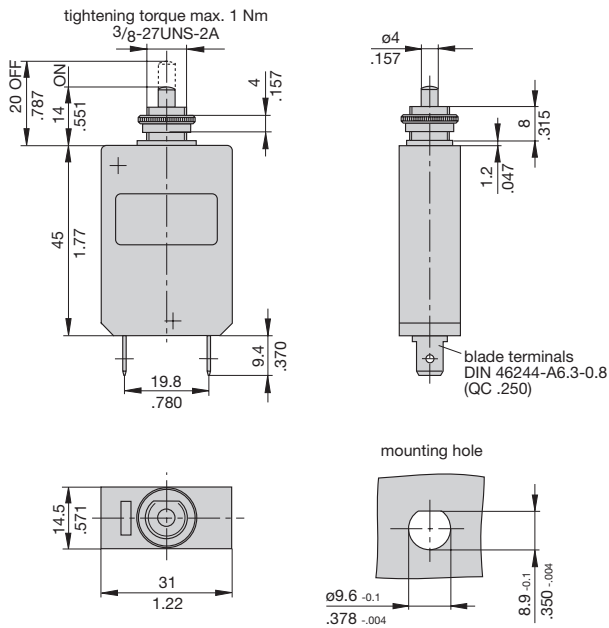

158-P10

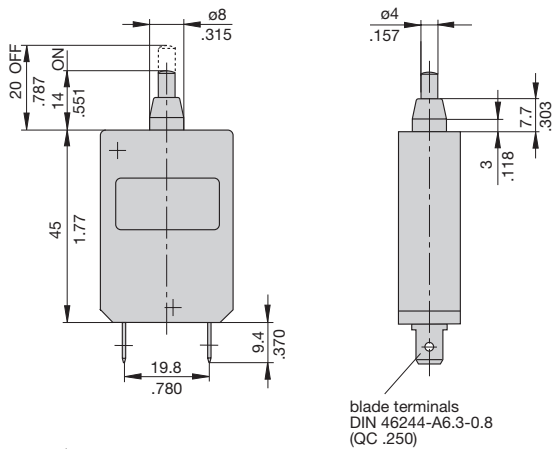

157/158-K10

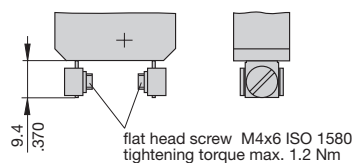

Internal connection diagram

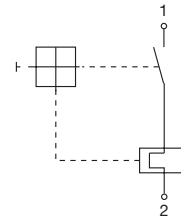

Typical time/current characteristics at +23°C/+73.4°F

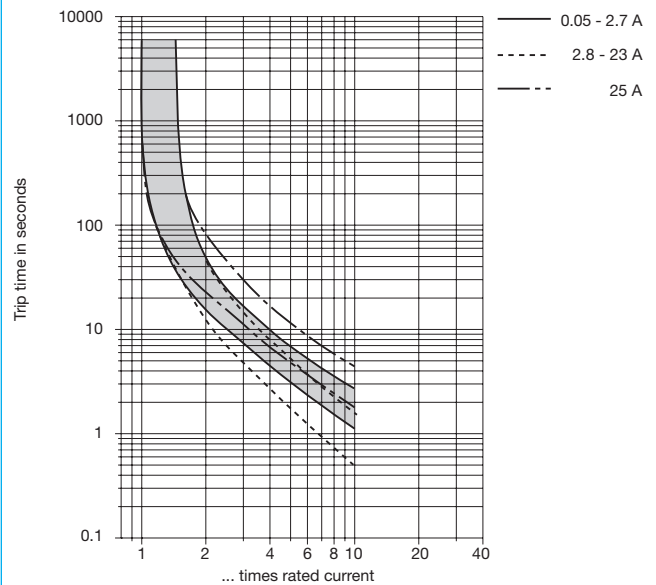

The time/current characteristic curve depends on the ambient temperature prevailing. In order to eliminate nuisance tripping, please multiply the circuit breaker current ratings by the derating factor shown below. See also section 9 – Technical information.

Ambient temperature °F	-4	+14	+32	+73.4	+104	+122	+140
°C	-20	-10	0	+23	+40	+50	+60
Derating factor	0.76	0.84	0.92	1	1.08	1.16	1.24

Installation drawings

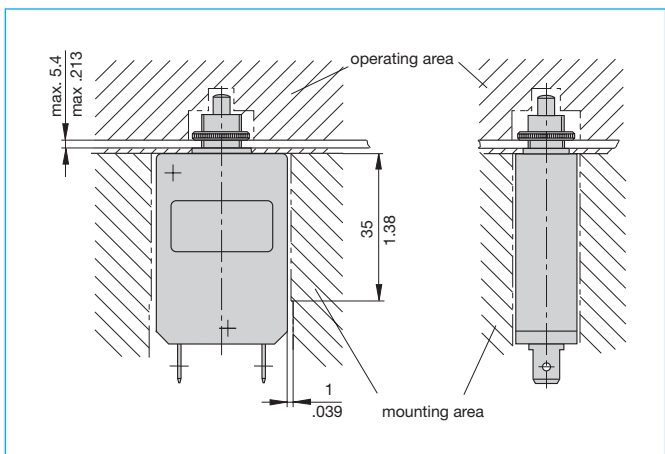

This is a metric design and millimeter dimensions take precedence (mm)
inch

Accessories

Mounting sockets

10F-P10 (up to 16 A max. load)

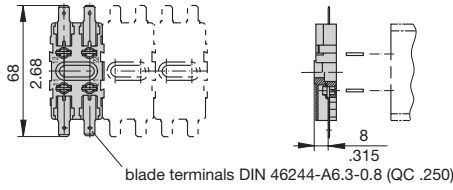

10F-K10 (up to 20 A max. load)

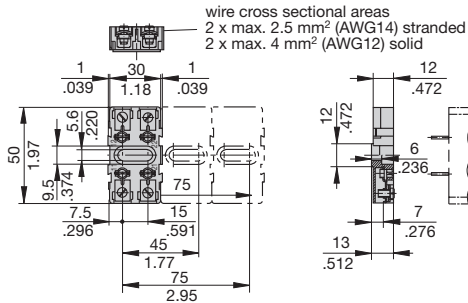

10F-A10 (up to 16 A max. load)

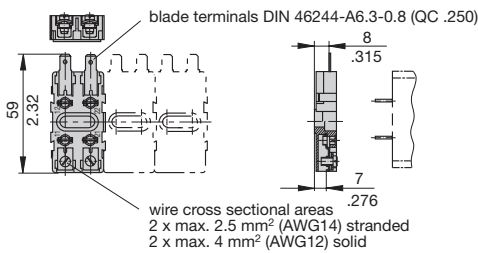

Accessories for sockets (up to 20 A max. load)

2-way bus bar **Y 301 166 02** 4-way bus bar **Y 301 166 01**

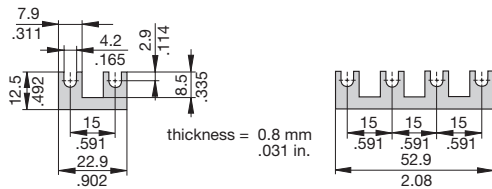

Connector bus links -K10

X 210 589 01/ 2.5 mm² (AWG 14), black (up to 20 A max. load)
X 210 589 02/ 1.5 mm² (AWG 16), brown (up to 13 A max. load)

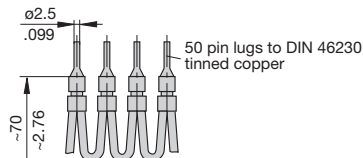

Connector bus links -P10

X 210 588 01/ 1.5 mm² (AWG 16), brown (up to 13 A max. load)
X 210 588 02/ 2.5 mm² (AWG 14), black (up to 20 A max. load)
X 210 588 03/ 2.5 mm² (AWG 14), red (up to 20 A max. load)
X 210 588 04/ 2.5 mm² (AWG 14), blue (up to 20 A max. load)

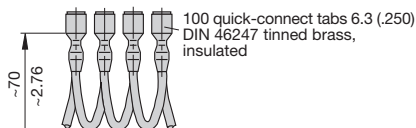

Accessories for type 157-...

Front panel water splash cover, transparent Y 300 538 01 and knurled nut Y 300 628 01
X 200 799 01 (bonded to nut) (IP64)

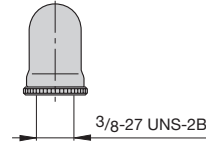

Front panel water splash cover, transparent with special knurled nut
X 200 798 02 (bonded to nut) (IP64)

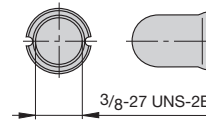

Splash cover (black) with hex nut (IP64)
X 210 739 01

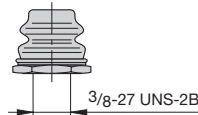

This is a metric design and millimeter dimensions take precedence ($\frac{\text{mm}}{\text{inch}}$)

All dimensions without tolerances are for reference only. In the interest of improved design, performance and cost effectiveness the right to make changes in these specifications without notice is reserved. Product markings may not be exactly as the ordering codes. Errors and omissions excepted.