

DRAWING NUMBER  
R 4004-XX

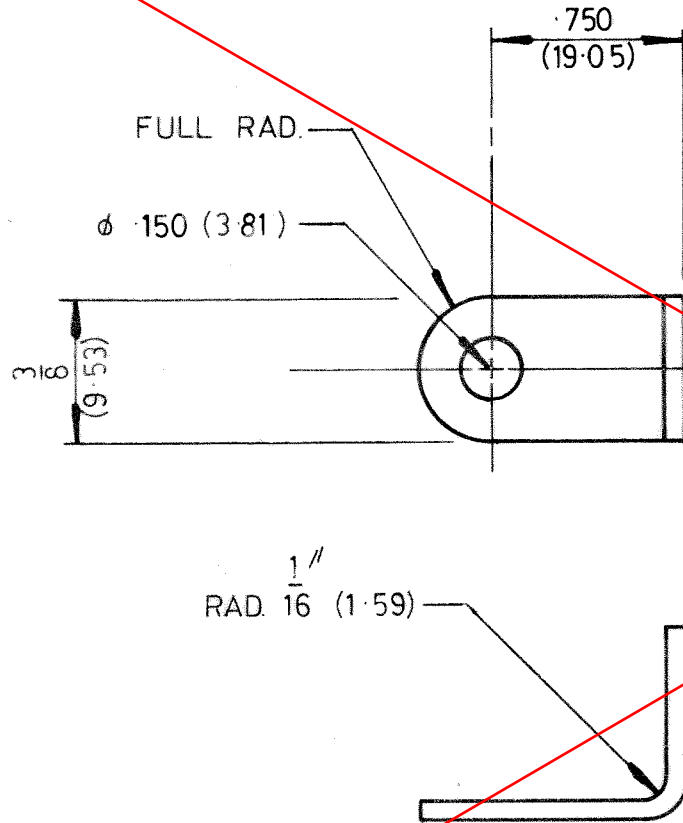

THIRD ANGLE PROJECTION

**OBSELETE**



DEVELOPED LENGTH — 1.380 (35.05) *Ref only.*

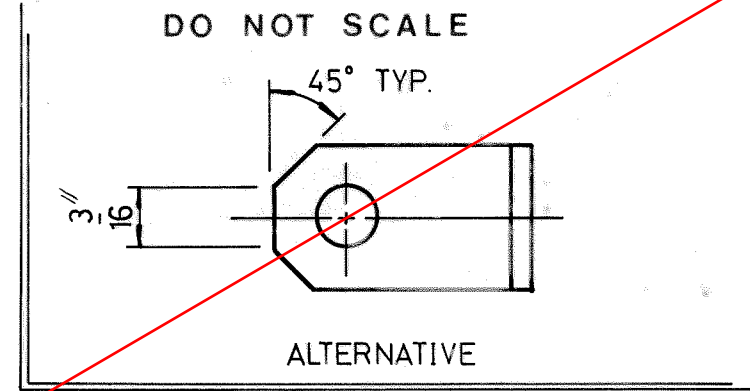
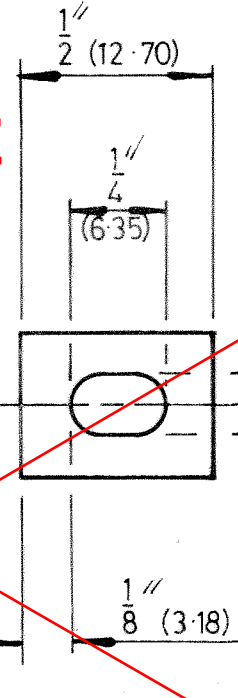

+005  
-000 (3.81)  
-150

11	18.3.88	1260
10	22.11.78	WAS MA 1138
9	1.12.76	380
8	29.176	349
7	28.11.73	235
<b>ISS. DATE CHANGE</b>		

APPD.	<i>[Signature]</i>
CHKD.	<i>[Signature]</i>
DRAWN	<i>[Signature]</i>
HOLD	REF. R4004

R4004-03	ZINC PLATE F0301 & CLEAR PASS.
R4004-00	_____
DRAWING N°	FINISH

**HARWIN ENGINEERS S.A.**  
PORTSMOUTH PO6 IRT

MATERIAL 18 SWG. M.S.

FINISH SEE ABOVE

TITLE  
MOUNTING BRACKET

TOLERANCES  
FRAC. ± 1/64 DEC ± .005 MM ±  
DIMS. IN INCH (mm) SCALE \_\_\_\_\_

DRAWING NUMBER  
R 4004-XX