

Dimensions in mm

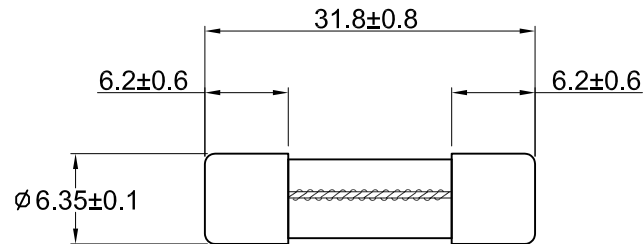

MMG63



MMG63-PA

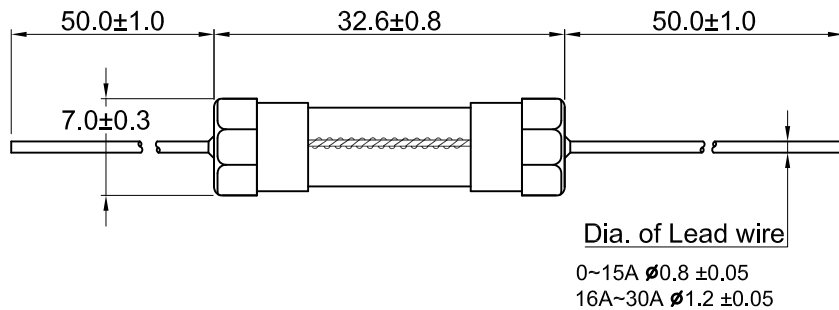

MMG63-PR

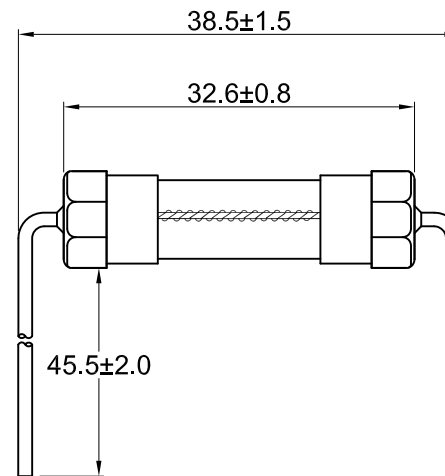

Rated Current	Breaking capacity	Rated Voltage	MMG63-PR/PA		
			UL LISTED	UL JET	
100mA	@125V/AC 10KA @250V/AC 35A	125V/250V			
125mA		125V/250V			
160mA		125V/250V			
200mA		125V/250V			
250mA		125V/250V			
300mA		125V/250V			
315mA		125V/250V			
400mA		125V/250V			
500mA		125V/250V			
600mA		125V/250V			
630mA	125V/250V				
700mA	125V/250V				
800mA	125V/250V				
1A	@125V/AC 10KA @250V/AC 100A	125V/250V	○	○	
1.25A		125V/250V			
1.5A		125V/250V			
1.6A		125V/250V			
2A		125V/250V			
2.5A		125V/250V			
3A		125V/250V			
3.15A		125V/250V			
3.5A		125V/250V			
4A		@125V/AC 10KA @250V/AC 200A	125V/250V		
5A	125V/250V				
6A	125V/250V				
6.3A	125V/250V				
7A	125V/250V				
8A	125V/250V				
10A	125V/250V				
12A	@32V/AC 1000A		32V		
13A			32V		
15A			32V		
16A		32V			
20A		32V			
25A		32V			
30A		32V			

Test Specification according to standard
UL 248-1,14

Electrical Characteristic

Rated Current	1.0In	1.35In	2.0In	
	In	Min.	Max.	Max.
100mA-30A	4 h	3600 s	3 s	120 s

<small>UNLESS OTHERWISE SPECIFIED DIMENSIONS ARE IN mm TOLERANCE DECIMALS ANGULAR X ± 0.5 ± 2° XX ± 0.25 DO NOT SCALE DRAWING</small>	CUSTOMER NO.		
	DRAWN BY Tim		TITLE
	CHECKED BY 林進有		Miniature Cartridge Fuse 6.35x32mm Slow Blow Type
	APPROVED BY 楊華元		PART NO. MMG63 MMG63- PA /PR
P/N MMG63ax.xxx	DATE 2017.09.19	DRAWING NO. AA05062111	
REV C	SCALE		