

SR253 Series
Digital Controller
Instruction Manual

Thank you for purchasing the Shimaden SR253 Series. Please check that the delivered product is the correct item you ordered. Please do not begin operating this product until you have read this instruction manual thoroughly and understand its contents.

SHIMADEN CO., LTD.

SR253F-1BE
NOV. 2001

“Notice”

Please ensure that this instruction manual is given to the final user of the instrument.

Preface

This instruction manual is meant for those who will be involved in the wiring, installation, operation and routine maintenance of the SR253 series. This manual describes the care, installation and wiring procedures for the operation series. Keep this manual at the work site during operation of the SR253 series. While using this instrument, you should always follow the guidance provided herein.

For matters regarding safety, potential damage to equipment and/or facilities, additional instructions are indicated by the following headings:

WARNING

Exercise extreme caution as indicated. This heading indicates hazardous conditions that could cause injury or death of personnel.

CAUTION

Exercise extreme caution as indicated. This heading indicates hazardous conditions that could cause damage to equipment and/or facilities.

NOTE

This heading indicates additional instruction and/or notes.

For matters regarding safety

Warning

SR253 series controller is designed for controlling temperature, humidity and other physical subjects. It must not be used in any way that may adversely affect the safety, health or working conditions of those who come into contact with the effects of its usage. When used, adequate and effective safety countermeasures must be provided at all times. No warranty, express or implied, is valid in the case of using this product without the use of proper safety countermeasures correspondingly.



Warning

- Before you start to use this instrument, place it in a control panel or the like and avoid touching the terminals.
- You should not draw the instrument out of its case nor should you put your hand or any dielectric into said case. Such an act may result in death or serious bodily injury from electric shock.

Caution

To avoid damage to the connected equipment, facilities or the product itself due to a fault of the product, safety countermeasure must be taken before usage, such as proper installation of the fuse and the overheating protection device. No warranty, express or implied, is valid in the case of usage without having implemented proper safety countermeasures.

Caution

- The  mark on the plate affixed to the instrument:
On the nameplate affixed to the case of your instrument, the  mark is printed. This is to warn you of the risk of electrical shock which may result if the charger is touched while it is energized.
- A means to allow the power to be turned off, such as a switch or a breaker, should be installed in the external power circuit to be connected to the power terminal of the instrument.
Fix the switch or the breaker adjacently to the instrument in a position which allows it to be operated with ease, and with an indication that it is a means of turning the power off.
- Fuse:
Since the instrument does not have a built-in fuse, do not forget to install a fuse in the power circuit to be connected to the power terminal.
Fuse Rating: 250V AC 1.0A/medium lagged or lagged type
- When you wire, tighten the terminal connections firmly.
- Use the instrument with a power voltage and frequency within their rated ranges.
- A voltage/current different from that of the input specification should not be added on the input terminal. It may reduce the life of the product and/or result in problems with the product.
- Voltage/current of a load to be connected to the output terminal should be within a rated range. Otherwise, the temperature will rise and reduce the life of the product and/or result in problems with the product.
- The SR253 series controller is provided with a draft hole for heat discharge. Take care to prevent metal or other foreign matter from obstructing it. Failure to do so may result in problems with the product.
- Do not block the draft hole or allow dust or the like to adhere to it. Any rise in temperature or insulation failure may result in a shortening of the life of product and/or problems with the product.
- It should be noted that repeated tolerance tests against voltage, noise, surge, etc., may lead to deterioration of the instrument.
- Remodeling the instrument or using it in an anomalous way is prohibited.
- For safe and proper use of the instrument, observe the instructions described in this manual.

Contents

	Page
1. Introduction	1
1-1. Check before use	1
1) Confirmation of model codes.....	1
2) Checking accessories	1
1-2. Caution for use.....	1
2. Installation	2
2-1. Installation site.....	2
2-2. Mounting	2
2-3. External dimensions and panel cutout	2
1) SR253 External dimensions and panel cutout	2
2) Dimension of current transformer (CT) for heater break alarm	2
2-4. Wiring.....	3
2-5. Terminal arrangement diagram	4
2-6. Terminal arrangement table.....	4
3. Front Panel.....	5
3-1. Diagram of front panel and names of parts	5
3-2. Instruction for front panel	5
4. Key Switch Operation and Description of Screens	6
4-1. Application of power	6
4-2. How to move LCD screens and cursor	6
4-3. Data change and registration	6
1) Change of numerical value	6
2) Change of letter (condition or the like)	6
5. LCD Screen Parameter Diagram	7
6. Functions of the Respective Groups	8
6-1. Lock/Initialization group (Group 8)	8~9
1) Setting of keylock	8
2) Setting of screen return time	8
3) Setting of initialization	9
4) Setting of mode	9
6-2. Unit/Measuring range group (Group 7).....	10~13
1) Setting of the PV bias	10
2) Setting of the PV filter	10
3) Setting of R.T.D. type	11
4) Setting of reference junction compensation	11
5) Setting of measuring unit	11
6) Setting of rounding of lowest decimal place	11
7) Setting of range	12~13
8) Setting of decimal point	13
9) Setting of PV scaling	13
6-3. Output group (Group 6)	14~15
1) Setting of output characteristics (direct action/reverse action)	14
2) Setting of output cycle	15
3) Setting of output against Scale Over.....	15
6-4. Option group (Group 5)	16~20
◎ Matters Related to the Setting of Analog Output	
1) Setting of analog output assignment	17
2) Setting of analog output scaling	17
◎ Matters Related to Setting of DI	
3) Setting of DI assignment	18
◎ Matters Related to Setting of Heater Break Alarm	
4) Display of CT current	19
5) Setting of current value for the heater break alarm	19
6) Setting of current value for the heater loop alarm	19
7) Setting of the heater break/loop alarm mode	20
◎ Matters Related to Setting for Communication Environment	
8) Communication-related setting	20
6-5. Event/DO group (Group 4).....	21~25
1) Setting of event action and DO action mode	22
2) Setting of action point.....	23
3) Setting of action hysteresis	23
4) Setting of delay time	24
5) Setting of inhibit action	25
6) Setting of output characteristics.....	25

6-6. PID group (Group 3).....	26~30
1) Setting of proportional band (P)	27
2) Setting of action hysteresis (DF)	27
3) Setting of integral time (I)	27
4) Setting of differential time (D)	27
5) Setting of manual reset (MR).....	28
6) Setting of zone	28
7) Setting of dead band	29
8) Setting of output limit	29
9) Setting of zone hysteresis	30
10)Setting of zone PID mode	30
11)Setting of remote PID No.	30
12)Setting of target value function.....	30
6-7. SV/Remote/Ramp group (Group 2)	31~36
◎ Matters Related to SV Setting	
1) Setting of set value (SV)	31
2) Setting of SV limits	32
3) Setting of selection/switch of multi-SV No.	32
◎ Matters Related to Remote Setting	
4) Setting of remote bias	32
5) Setting of remote filter	32
6) Setting of remote scale	33
7) Setting of remote mode	33, 34
8) Setting of remote tracking.....	34
9) Setting of remote proportional coefficient	35
10)Setting of remote linear delay time.....	35
◎ Matters Related to Ramp Setting	
11)Setting of ramp value	35
12) Setting of ramp unit	36
13)Setting of ramp rate.....	36
6-8. Control group (Group 1).....	37~39
1) Execution/stop of auto tuning (AT)	37
2) Setting of auto tuning point.....	38
3) Auto/manual of control output.....	38
4) Execution/standby of control	39
5) Stop/restart of ramp control	39
6) Selection of communication	39
6-9. Monitor group (Group 0).....	40~41
1) Explanation about group 0-0 screen	40
2) Setting of SV value	40
3) Switching of SV No. in execution	40
4) Switching to remote SV	41
5) Explanation about group 0-1 screen	41
6) Explanation about group 0-2 screen	41
7. External Input/Output	42
8. Connecting Devices for Instrument Terminals.....	43
8-1. 24-pin plug	43
8-2. Multi-SV No. switching device	43
9. Error Messages (PV Display).....	44
9-1. Problems found in check-up upon application of power	44
9-2. Problems with PV Input	44
10. List of Parameters.....	45~51
11. Sheet for Recording Set Parameters	52, 53
12. Specifications	54~58

1. Introduction

1-1. Check before use

This product has been fully checked for quality assurance prior to shipment. Nevertheless, you are requested to make sure that there is no error, damage or shortage of delivered items by confirming the model codes and checking the external view of the product and the number of accessories.

1) Confirmation of model codes

Check the model codes stuck to the case of the product to ascertain if the respective codes designate what was specified when you ordered the product, referring to the following code table:

SR253- <input type="checkbox"/> <input type="checkbox"/> - <input type="checkbox"/> <input type="checkbox"/> - <input type="checkbox"/> <input type="checkbox"/> <input type="checkbox"/> <input type="checkbox"/> <input type="checkbox"/> <input type="checkbox"/> <input type="checkbox"/> <input type="checkbox"/>	Item	Code and Description
	1. Series	MPU loaded, Multi-function controller
	2. Input	1: Thermocouple 2: R.T.D 3: Voltage (mV) 4: Current (mA) 6: Voltage (V)
	3. Output 1	Y: Contact I: Current P: SSR drive voltage V: Voltage
	4. Output 2	N: Without Y: Contact I: Current P: SSR drive voltage V: Voltage
	5. Event output/heater break alarm	0: Without 1: Event contact output - 3 points 2: Event contact output - 3 points + heater break alarm (heater current 30A) 3: Event contact output - 3 points + heater break alarm (heater current 50A)
	6. Remote setting input	04: 4~20mA DC (not insulated) 14: 4~20mA DC (insulated) 05: 1~5V DC (not insulated) 15: 1~5V DC (insulated) 06: 0~10V DC (not insulated) 16: 0~10V DC (insulated) (Standard: 06)
	7. Analog output	00: Without 13: One output 0~10mV DC 23: Two outputs 0~10mV DC 14: One output 4~20mA DC 24: Two outputs 4~20mA DC 16: One output 0~10V DC 26: Two outputs 0~10V DC
	8. External input and output control signal	0: Without 1: With 2: With (Cord equipped)
	9. Communicative interface	0: Without 5: RS-485 6: RS-442A 7: RS-232C
	10. Remarks	0: Without 9: With

2) Checking accessories

Standard accessories

- (1) Instruction manual 1 set
- (2) Unit decal 1 sheet

Optional accessories

- (1) Current transformer (CT) for heater break alarm : To be equipped when the apparatus has a heater break alarm option
 - When Code 2 is selected (30A) - Model CTL-6-S 1 pc.
 - When Code 3 is selected (50A) - Model CTL-12-S36-8 1 pc.
- (2) 24-pin plugs: To be attached when the instrument is equipped with external input and output control signal option
 - When Code 1 is selected - 24-pin plug, clamp filter 1 set
 - When Code 2 is selected - 24-pin plug, 1 m cord (with crimp terminal), clamp filter 1 set

Note 1: Contact our representative or our local office concerning any problems with the product, accessories or related items.

1-2. Caution for use

- (1) Avoid operating keys of the front panel with hard or sharp objects or motions. Lightly touch the operating key with finger tip for operation.
- (2) Avoid using solvents such as thinner; wipe gently with a dry cloth.

2. Installation

2-1. Installation site

⚠ Caution

In the case where there is an intention to operate this product at one of the following sites, be aware that the occurrence of fire and/or other dangerous situations is considerable.
Exercise caution and avoid these places when selecting an operational site.

- (1) Any place where inflammable or corrosive gas, dust or smoke is generated, or is filled with same.
- (2) Any place exposed to water, sunlight or high radiant heat from other equipment.
- (3) Any place where the ambient temperature for the instrument is below -10°C or above 50°C.
- (4) Any place where the instrument is in close proximity to a device which generates high frequency waves.
- (5) Where highly intense vibration or impact is generated or transferred.
- (6) Where the relative humidity is 90%RH or below dew point.
- (7) Where the elevation is in excess of 2,000 m.

2-2. Mounting

⚠ Caution

For safety's sake and to maintain the functional level expected of the product, do not remove it from its case.
If it is required to be removed from its case for replacement or for repair, contact our business office in your neighborhood.

- (1) Machine the mounting hole by referring to panel cutout below.
- (2) Applicable thickness of the mounting panel is from 1.0 to 4.5 mm.
- (3) As this product provides mounting fixture, insert the product from the front panel for installation.

2-3. External dimensions and panel cutout

1) SR253 External dimensions and panel cutout

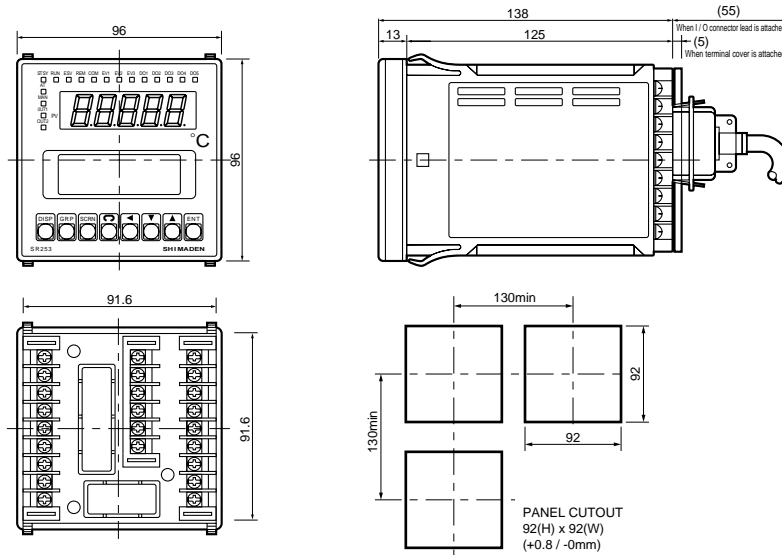

2) Dimension of current transformer (CT) for heater break alarm



2-4. Wiring

⚠ Caution

- Always disconnect this product from any power source during wiring operation to prevent electrical shock.
- Avoid touching the wired terminal and charged devices while supplying power.

- (1) Wiring operation should be done according to the instruction for the terminal arrangement in section 2-5. Exercise care that no wrong connection is made.
- (2) Crimp terminal should accommodate the M3.5 screw and should have a width of less than 7 mm.

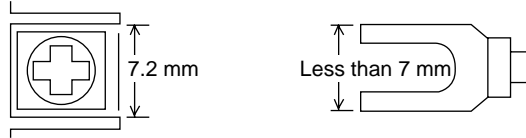

- (3) For thermocouple input, select the compensation wire suitable to the thermocouple type.
- (4) For R.T.D input, leads should be less than 5 Ω in resistance and three leads should have the same resistance.
- (5) Input signal line should be conducted safely apart from the high voltage power line.
- (6) Shield wiring (single point grounding) is effective for static induction noise.
- (7) Short interval twisted pair wire for input signal is effective for electromagnetic induction noise.
- (8) When wiring, use wire (1 mm² minimum in sectional area) of 600V Grade Polyvinyl Chloride insulated wire or equivalent wire which has the same ratings.
- (9) Earth grounding should be performed with earth resistance less than 100 Ω and with wire thicker than 2 mm².
- (10) Terminal cover

A terminal cover is attached to the terminal portion of the instrument. It is detached easily when lateral force is applied.

During a wiring operation, it should be removed. Once wiring is completed, re-attach it reliably by pressing it into the top and bottom grooves in the terminal portion.

- (11) Noise filter

If the instrument appears to have noise interference caused by the power supply, use a noise filter to prevent erroneous functioning.

Install a noise filter on the grounded panel and make the wire connecting the noise filter OUT terminal and the power supply terminal on the controller as short as possible.

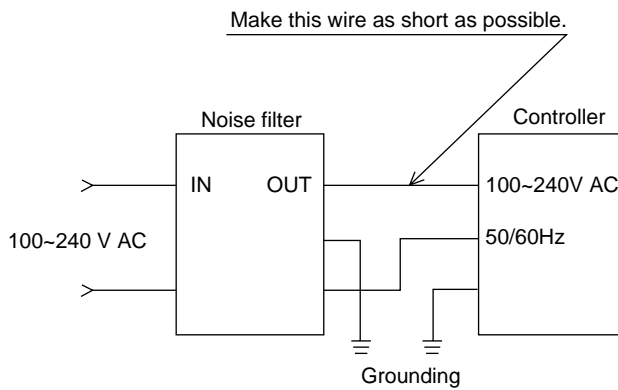

Recommended noise filter: TDK ZMB2203-13

2-5. Terminal arrangement diagram

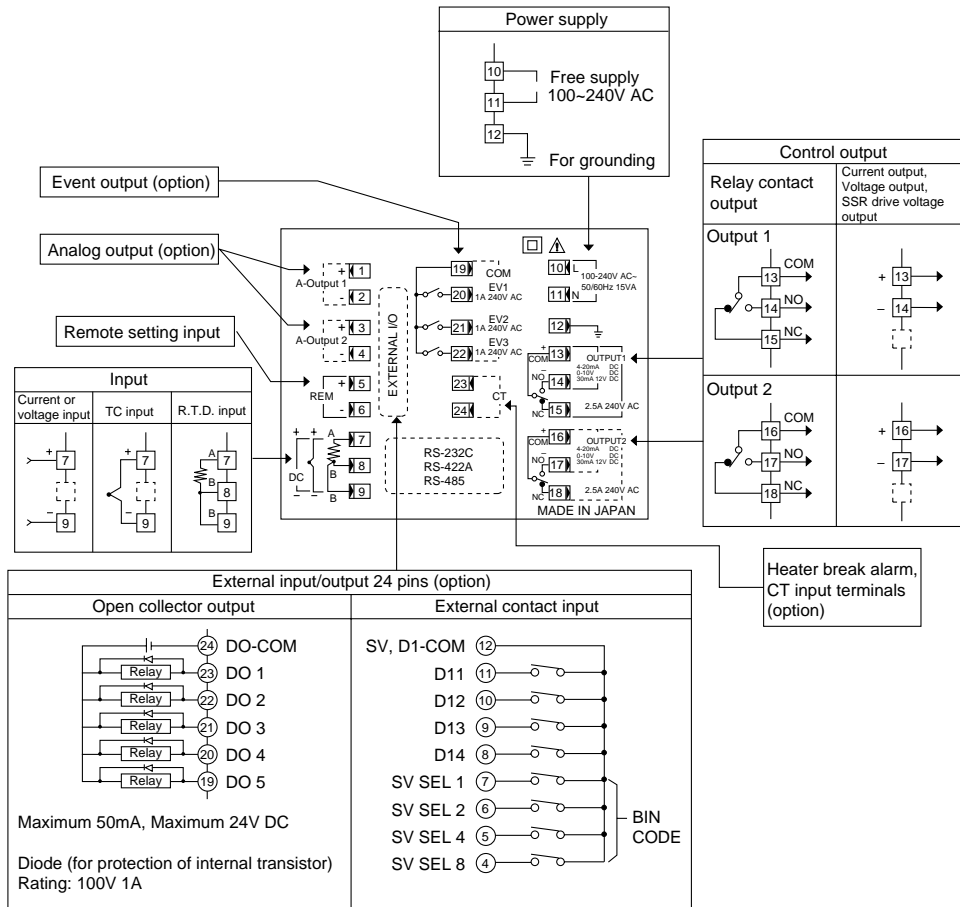

2-6. Terminal arrangement table





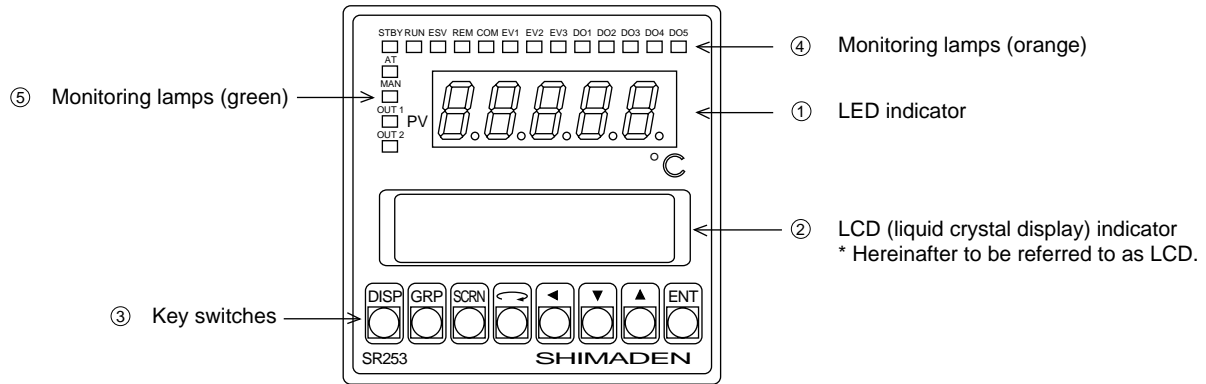

Name of terminal	Terminal No.	Description	
Analog output terminal (No.1) (option)	1	+ } Analog output (No.1)	
	2		- }
Analog output terminal (No.2) (option)	3	+ } Analog output (No.2)	
	4		- }
Remote setting input terminal	5	+ } Remote setting input	
	6		- }
Input terminal	7	A } R.T.D.	
	8		B }
	9		B }
	9	+ } Voltage, current or thermocouple input	
Power terminal	10	L } AC power supply	
	11		N }
Grounding terminal	12	Grounding	
Control output terminal (No.1)	13	COM Common } Contact output	
	14		NO Normal open }
	15		NC Normal close }
	13	+ } Voltage, current or SSR drive output	
	14		- }
Control output terminal (No.2) (option)	16	COM Common } Contact output	
	17		NO Normal open }
	18		NC Normal close }
	16	+ } Voltage, current or SSR drive output	
	17		- }
Event, heater break alarm output terminal (option)	19	COM Common } Normal close is also possible depending on parameter setting.	
	20		NO Normal open (EV1) }
	21		NO Normal open (EV2) }
	22		NO Normal open (EV3) }
Heater break alarm CT input terminal (option)	23	CT input	
	24		

3. Front Panel

3-1. Diagram of front panel and names of parts



3-2. Instruction for front panel

- ① LED indicator
- (1) Measured (PV) value display
Displays current measured value.
 - (2) Error message display
Displays an appropriate message in the case of an error (such as Scale Over).
- ② LCD indicator
- (1) Set (SV) No. display
Displays current SV No.
 - (2) Set (SV) value display
Displays current SV value.
 - (3) PID No. display
Displays current PID No.
 - (4) Output display
Displays control output value in bar graph (%) and numerically (%).
 - (5) Deviation display
Displays difference (deviation) between PV value and SV value in bar graph (%) and numerically (%).
 - (6) Set parameter display
Displays various set parameters as selected by front key operation. (21 characters x 4 lines)
- ③ Key switches
- (1) **DISP** (display key)
For use to return to the initial screen of the monitor group.
 - (2) **GRP** (group key)
For use to move between groups.
 - (3) **SCRn** (screen key)
For use to move within a group.
 - (4)  (parameter key)
For use to move the cursor ().
 : This cursor blinks continuously.
 - (5)  (shift key)
For use to move from digit to digit of set value.
 - (6)  (down key)
For use to decrease a number in setting a parameter value or data.
 - (7)  (up key)
For use to increase a number in setting a parameter value or data.
 - (8) **ENT** (entry key)
For use to register a parameter value or data.
- ④ Monitoring lamps (orange)
- (1) EV1
Lights when EV1 is on.
 -
 -
 -
 - (8) DO5
Lights when DO5 is on.
- ⑤ Monitoring lamps (green)
- (1) AT
Flashes during the execution of auto tuning.
 - (2) MAN
Flashes during manual operation of control output.
 - (3) OUT1
For current or voltage output, the brightness of the lamp changes in proportion to the strength of control output 1. For contact or SSR drive voltage output, the lamp lights when control output 1 turns on and goes out when it turns off.
 - (4) OUT2
For current or voltage output, the brightness of the lamp changes in proportion to the strength of control output 2. For contact or SSR drive voltage output, the lamp lights when control output 2 turns on, and the lamp goes out when it turns off.
 - (5) STBY
In execution/standby control, this lamp lights when output is held in a standby (STANBY) state.
 - (6) RUN
Flashes during the execution of ramp control. It lights when ramp control is temporarily stopped.
 - (7) ESV
Lights when external switch (EXT) is set in multi-SV No. selection/switching.
 - (8) REM
Lights when remote setting (REM) is set in SV No. selection.
 - (9) COM
Lights when parameters or the like are set via communication (COM).

4. Key Switch Operation and Description of Screens

4-1. Application of power

Upon applying power, on the LCD display the following initial screens appear for about 1.5 seconds each, followed by the initial screen of the monitor group. On these initial screens, confirm that this instrument is as specified when your original order was placed.

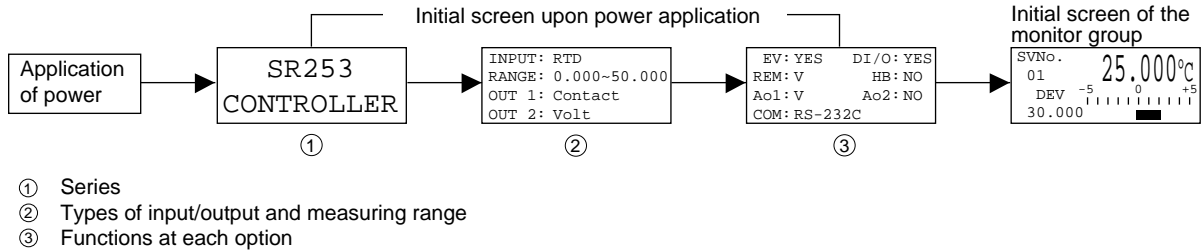

4-2. How to move LCD screens and cursor

- (1) Moving to initial screen of monitor group
Pressing the **DISP** key calls the initial screen of the monitor group onto the display.
- (2) Moving from group to group
To move from one group to another group, press the **GRP** key in the initial screen of the group.
- (3) Moving to the first screen of a group
When the **GRP** key is pressed in a screen of any group other than the monitor group, the initial screen of that group is displayed.
- (4) Moving within a group
Pressing the **SCRN** key calls screens of the group one by one in order.
- (5) Moving the cursor on the screen
When two or more parameters are shown in a screen, pressing the key moves the cursor (flashes) to the next parameter.

4-3. Data change and registration

1) Change of numerical value

When there are two or more parameters, press the key to move the cursor () to the parameter to be changed. When the key is pressed, the rightmost digit of the value flashes. Further pressing the key moves the flashing figure to a digit whose figure is to be changed. Use the or key to change the figure. Press the **ENT** key to register the data after confirming that the changed value is correct. Upon registration of the data, the flashing stops. (The punctuation mark ":" turns to "=" while a change is being made.)

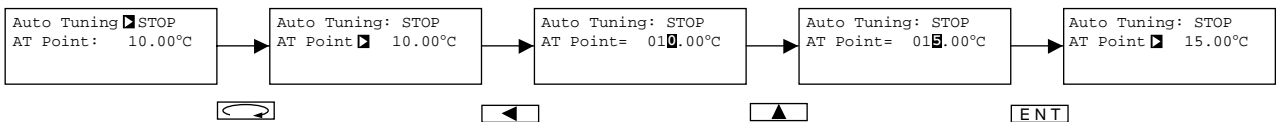

2) Change of letter (condition or the like)

When there are two or more parameters, press the key to move the cursor () to the parameter to be changed. Use the or key to change to a desired condition. Press the **ENT** key to register the data after confirming that the change has been made correctly. Upon registration of the data, the letters stop flashing. (The punctuation mark ":" turns to "=" while a change is being made.)

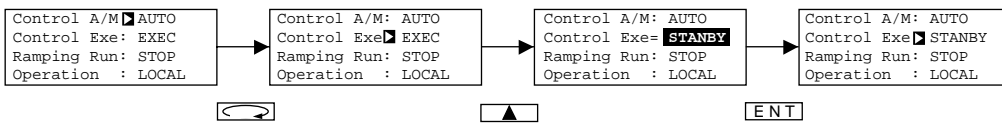

5. LCD Screen Parameter Diagram

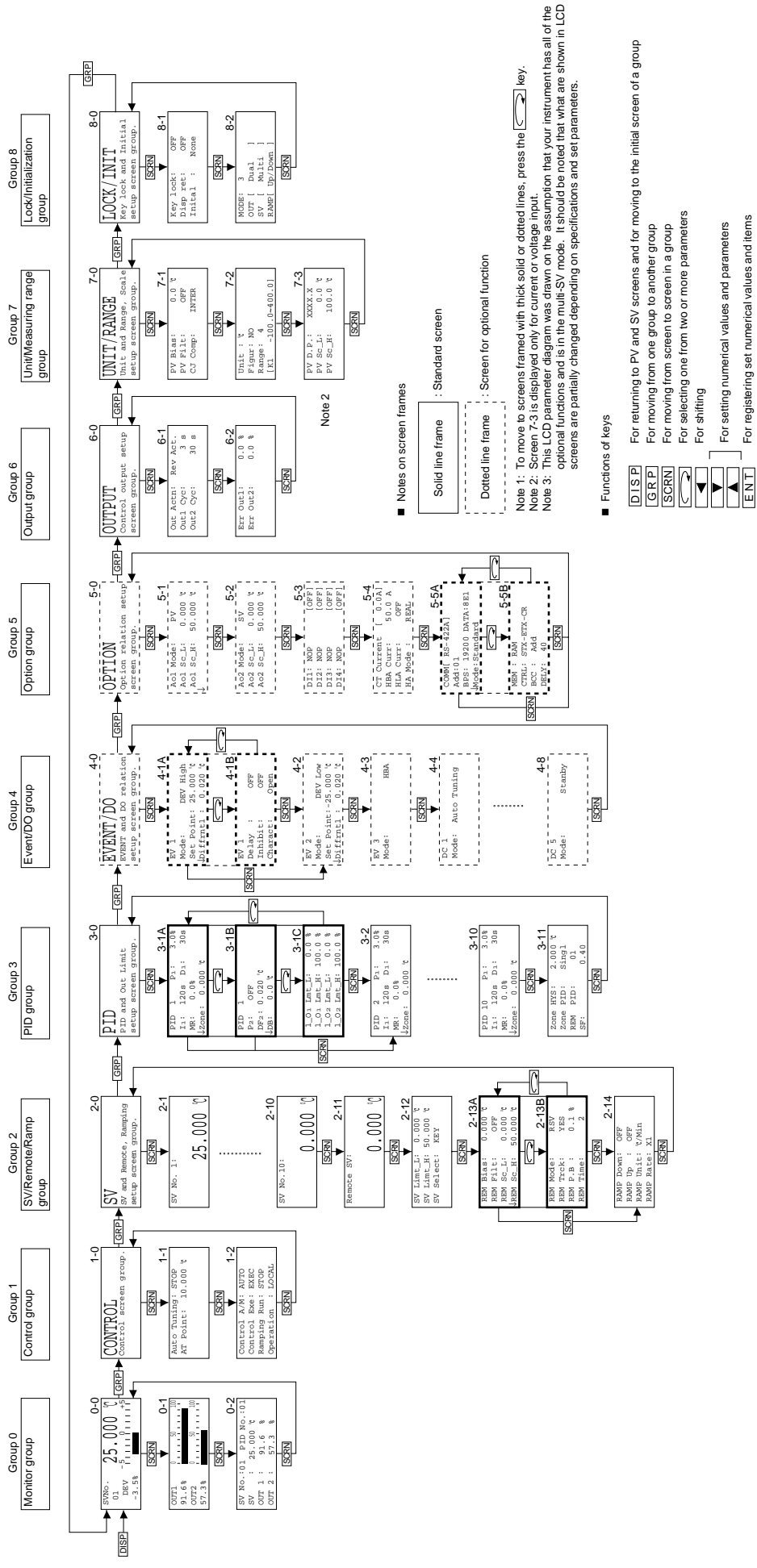

6. Functions of the Respective Groups

In Chapter 6, the basic operations of this instrument and the setting procedure are described. Follow the procedure, referring to the LCD screen parameter diagram in Chapter 5.

6-1. Lock/Initialization group (Group 8)

Press the **GRP** key to call the LOCK/INIT screen (Group 8-0) onto display. Then press the **SCRN** key to move to a screen in which a setting or a change is to be made. Use the  key for selecting a parameter on the screen.

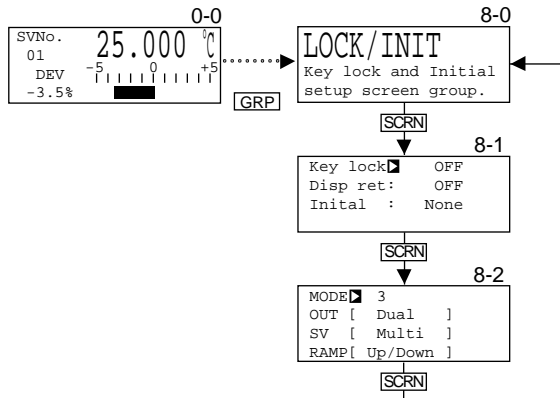

1) Setting of keylock (Group 8-1)

Key lock	OFF
Disp ret	60 s
Initial	None

Setting range: OFF, Lock1, Lock2, Lock3
Initial value: OFF

In order to avoid an unintended data change by erroneous operation, a keylock selected one from Lock1, Lock2 and Lock3 is applied. When locked, each of the affected LCD screens shows the  mark on the top left. (The keylock parameter is not locked, though.)

Lock1..... Parameters except SV, AT, MANUAL and STANBY are locked.

Lock2..... Parameters except SV are locked.

Lock3..... All parameters are locked.

(For more details, see the list of parameters in Chapter 10.)

2) Setting of screen return time (Group 8-1)

Key lock	OFF
Disp ret	60 s
Initial	None

Setting range: OFF, 10~120 sec.
Initial value: 60 sec.

This is the function to automatically return to the initial screen of the monitor group (0-0) when none of the keys are operated during a screen return time set. (This will not function in the screens of Group 0-1 and 0-2.)

3) Setting of initialization (Group 8-1)

Key lock:	OFF
Disp ret:	60 s
Initial	<input checked="" type="checkbox"/> None

Setting range: None, Exe1, Exe2
Initial value: None

This is the function to return registered set data to its initial value.

None: No initialization.

Exe1: Only the parameters shown in the following Table 1 are initialized. (For more details, see the list of parameters in Chapter 10.)

Exe2: All the parameters of each group are initialized.

Table 1 Parameters to be initialized by selecting Exe1

CONTROL Group (Group 1)	SV/Remote/Ramp group (Group 2)	PID group (Group 3)	EVENT/DO group (Group 4)
Auto Tuning AT Point Control A/M Ramping Run	Each SV value SV Limt_L SV Limt_H REM Bias REM Filt REM Sc_L REM Sc_H RAMP Down RAMP Up RAMP Unit RAMP Rate	All parameters except m_O1 Lmt_L, m_O1 Lmt_H, m_O2 Lmt_L, m_O2 Lmt_H, m=1~10	Set point of each EVENT/DO Diffrentl of each EVENT/DO
	} Note 1		
OPTION group (Group 5)	OPTION group (Group 6)	UNIT/RANGE group (Group 7)	LOCK/INIT group (Group 8)
Ao1 Sc_L Ao1 Sc_H Ao2 Sc_L Ao2 Sc_H	None	PV Bias PV Filt	None

Note 1: In case CTRL is selected in 6-7. 7) Setting of remote mode, these are not initialized even when Exe1 is executed.

4) Setting of mode (Group 8-2)

MODE	<input checked="" type="checkbox"/> 3
OUT	[Dual]
SV	[Multi]
RAMP	[Up/Down]

Setting range: One output type: Modes 0 and 2 (Modes 1 and 3 are not displayed)
Two output type: Modes 0, 1, 2 and 3
Initial value: One output type: Mode 2
Two output type: Mode 3

For selection from Modes 0 to 3, consult the following table showing control output, the number of SV setting points and whether or not ramp control is engaged.

	Control output (OUT)	Set value (SV)	Ramp control (RAMP)
MODE 0	Singl (1 output)	Singl (SV No.1, Remote SV)	----- (Unusable)
MODE 1	Dual (2 outputs)	Singl (SV No.1, Remote SV)	----- (Unusable)
MODE 2	Singl (1 output)	Multi (SV No.1~10, Remote SV)	Up/Down (Usable)
MODE 3	Dual (2 outputs)	Multi (SV No.1~10, Remote SV)	Up/Down (Usable)

Note 1: No change of mode is possible during the execution of AT or ramp control.

6-2. Unit/Measuring range group (Group 7)

(In this group, LCD screen configuration differs depending on the type of input.)

Call the UNIT/RANGE screen (Group 7-0) by the use of the **GRP** key and press the **SCRN** key to move to a screen in which setting or a change is to be made. Use the **←** key to select a parameter on the screen.

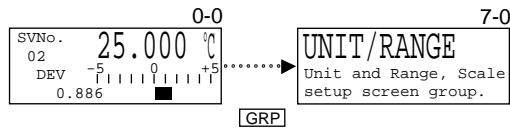

The screen configuration for each of the input types is shown below:

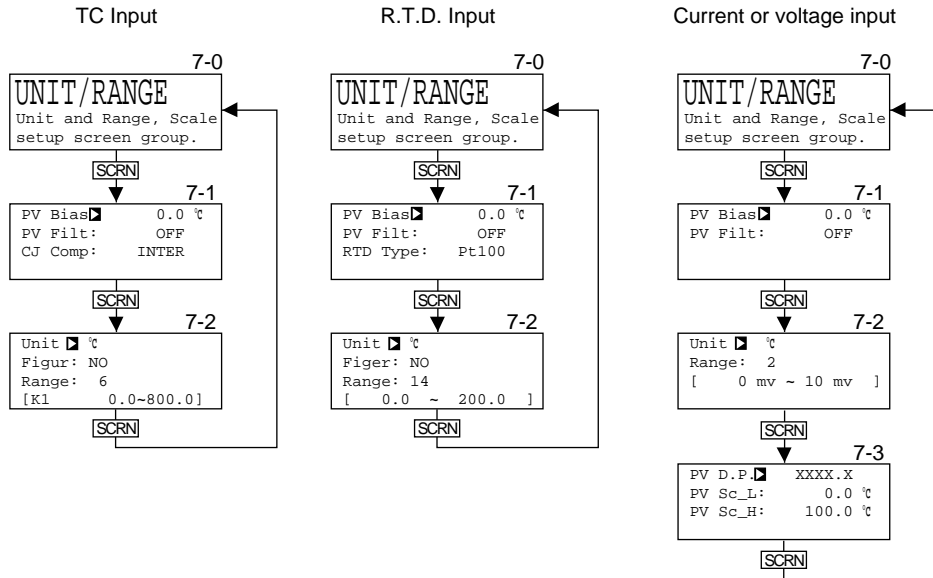

1) Setting of the PV bias (Group 7-1)

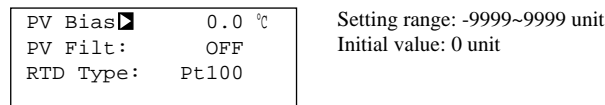

PV bias is the function of correcting the PV value display, that is, an error due to a sensor, instrument or the like is corrected so that the PV value comes in accord with a control temperature display, not an actual temperature display.

2) Setting of the PV filter (Group 7-1)

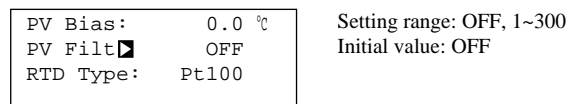

If a noise is included in the PV input, it may adversely affect control results due to the unsteadiness of the PV display. The PV filter is used to reduce such an effect and to stabilize control.

Filter operation is carried out by linear delay operation.

$$\text{Time constant } T \text{ (sec.)} = \text{set value} \times \text{sampling cycle (sec.) of the PV input}$$

From the above equation, $T = 300 \times 0.2 = 60 \text{ sec.}$

Thus, the PV filter with a time constant of 60 sec. maximum can be applied. Accordingly, the larger the set value, the longer the time constant and the more effectively noise can be removed.

It should be noted, however, that too large of a time constant may sometimes have a detrimental effect on the result of control in a highly responsive control system.

3) Setting of R.T.D. type (Group 7-1)

(This setting is only for R.T.D. input. The screen is not displayed in the case of TC or linear input.)

PV Bias:	0.0 °C	Setting range: JPt100, Pt100 Initial value: Pt100
PV Filt:	OFF	
RTD Type	Pt100	

Selection between Pt100 and JPt100 as the type of sensor R.T.D. used for input is made.

4) Setting of reference junction compensation (Group 7-1)

(This setting is only for TC input. The screen is not displayed in the case of R.T.D. or linear input.)

PV Bias:	0.0 °C	Setting range: INTER, EXTER Initial value: INTER
PV Filt:	OFF	
CJ Comp	INTER	

Selection is made as to whether reference junction compensation is carried out internally or externally. Usually, it is done in the instrument but it should be done externally if higher accuracy is required.

5) Setting of measuring unit (Group 7-2)

Unit	°C	Setting range: TC (thermocouple) input ; °C, °F, K R.T.D. (thermoreistance) input ; °C, °F Current or voltage input ; °C, °F, %, NONE (no indication of unit) Initial value: °C
Figur:	YES	
Range:	14	
[0.0 ~ 200.0]		

The unit of input is set.

Note 1: When this parameter setting is changed, Exe1 as an initialization setting is automatically brought into execution.

Note 2: In the case of TC input, changing from °C or °F to K automatically brings the range to 18.

Note 3: In the case of TC input, changing from K to °C or °F automatically brings the range to 6.

6) Setting of rounding of lowest decimal place (Group 7-2)

(This setting is only for TC or R.T.D. input. The screen is not displayed in the case of linear input.)

Unit :	°C	Setting range: YES, NO Initial value: YES
Figur	YES	
Range:	14	
[0.0 ~ 200.0]		

Whether or not to leave the lowest decimal place of set measuring range can be chosen by this setting. If your measuring range does not have functions, this function is of no use.

Figur: YES.....The number of display digits remains exactly as the set measuring range.

Figur: NOThe lowest decimal place of display digits set as the measuring range is rounded.

Note 1: A change in this parameter setting automatically brings Exe1 as the initialization setting into execution.

7) Setting of range (Group 7-2)

Unit :	°C
Figur:	YES
Range	14
[0.0 ~ 200.0]

A measuring range is selected from the following table.

Note 1: A change in this parameter setting automatically brings Exe1 as the initialization setting into execution.

■ Thermocouple input

Range No.	Type of input	Measuring range		
		°C	°F	K
1	B	0.0 ~ 1800.0	0 ~ 3300	_____
2	R	0.0 ~ 1700.0	0 ~ 3100	_____
3	S	0.0 ~ 1700.0	0 ~ 3100	_____
4	K	-100.0 ~ 400.0	-150.0 ~ 750.0	_____
5	K	0.0 ~ 400.0	0.0 ~ 750.0	_____
6	K	0.0 ~ 800.0	0.0 ~ 1500.0	_____
7	K	0.0 ~ 1200.0	0.0 ~ 2200.0	_____
8	K	-200.0 ~ 200.0	-300.0 ~ 400.0	_____
9	E	0.0 ~ 700.0	0.0 ~ 1300.0	_____
10	J	0.0 ~ 600.0	0.0 ~ 1100.0	_____
11	T	-200.0 ~ 200.0	-300.0 ~ 400.0	_____
12	N	0.0 ~ 1300.0	0.0 ~ 2300.0	_____
13	PL II	0.0 ~ 1300.0	0.0 ~ 2300.0	_____
14	PR40-20	0.0 ~ 1800.0	0 ~ 3300	_____
15	WRe5-26	0.0 ~ 2300.0	0 ~ 4200	_____
16	U	-200.0 ~ 200.0	-300.0 ~ 400.0	_____
17	L	0.0 ~ 600.0	0.0 ~ 1100.0	_____
18	K	_____	_____	10.0 ~ 350.0
19	Gold iron /chromel	_____	_____	0 ~ 350.0

Initial value: Range No.6
(K thermocouple 0.0~800.0°C)

Note 2: In the case of B thermocouple, accuracy is not guaranteed at temperatures below 400°C (750°F).

Note 3: The precision for PR40-20 is ±(0.3% FS+1°C)

Note 4: The precision for K thermocouple (Kelvin) is:
10.0~30.0 K: ±(0.75% FS+1K)
30.0~70.0 K: ±(0.30% FS+1K)
70.0~350.0 K: ±(0.25% FS+1K)

Note 5: The precision for the gold iron/chromel thermocouple is ±(0.25% FS+1K)

■ R.T.D. (Pt100/JPt100)

Range No.	Type of input	Measuring range	
		°C	°F
1	Pt100 (JPt100)	-200.0 ~ 600.0	-300.0 ~ 1100.0
		-200.0 ~ 500.0	-300.0 ~ 900.0
2	Common to Pt100 and JPt100	-100.00 ~ 100.00	-150.0 ~ 200.0
3		-100.0 ~ 100.0	-150.0 ~ 200.0
4		-100.0 ~ 300.0	-150.0 ~ 600.0
5		-60.00 ~ 40.00	-80.00 ~ 100.00
6		-50.00 ~ 50.00	-60.00 ~ 120.00
7		-40.00 ~ 60.00	-40.00 ~ 140.00
8		-20.00 ~ 80.00	0.00 ~ 180.00
9		0.000 ~ 50.000	0.00 ~ 120.00
10		0.00 ~ 50.00	0.00 ~ 120.00
11		0.00 ~ 100.00	0.00 ~ 200.00
12		0.0 ~ 100.0	0.0 ~ 200.0
13		0.00 ~ 200.00	0.0 ~ 400.0
14		0.0 ~ 200.0	0.0 ~ 400.0
15		0.0 ~ 300.0	0.0 ~ 600.0
16		Pt100 (JPt100)	0.0 ~ 500.0
	0.0 ~ 500.0		0.0 ~ 900.0

Initial value: Range No.14 (Pt100 0.0~200.0°C)

Note 6: The precision of 50°C (120°F) span input is ±0.2% FS.

■ Linear input (current or voltage)

Range No.	Voltage (mV)	Current (mA)	Voltage (V)
1	-10 ~ 10	————	-1 ~ 1
2	0 ~ 10	————	0 ~ 1
3	0 ~ 20	————	0 ~ 2
4	0 ~ 50	0 ~ 20	0 ~ 5
5	10 ~ 50	4 ~ 20	1 ~ 5
6	0 ~ 100	————	0 ~ 10
7	-100 ~ 100	————	-10 ~ 10

Initial value: Voltage (mV) input; Range No.2 (0~10mV)
 Current (mA) input; Range No.5 (4~20mA)
 Voltage (V) input; Range No.6 (0~10 V)

8) Setting of decimal point (Group 7-3)

(This setting is only for linear input. This screen is not displayed for R.T.D. or TC input.)

PV D.P. ▾	XXXX.X
PV Sc_L ▾	0.0 °C
PV Sc_H ▾	100.0 °C

Setting range: XXXXX~X.XXXX

Initial value: XXXX.X

In the case of voltage or current input, the position of decimal point in the PV display screen is set.

9) Setting of PV scaling (Group 7-3)

(This setting is only for linear input. This screen is not displayed for R.T.D. or TC input.)

PV D.P. :	XXXX.X
PV Sc_L ▾	0.0 °C
PV Sc_H ▾	100.0 °C

Selectable range : -19999~26000 unit

Measuring range : Minimum span 100 unit

Maximum span 25000 unit

Within the above range, any can be set (Sc_L<Sc_H should be satisfied, though).

Initial value: Sc_L ; 0 unit

Sc_H ; 1000 unit

PV D.P. :	XXXX.X
PV Sc_L :	0.0 °C
PV Sc_H ▾	100.0 °C

In the case of voltage or current input, set a measuring range (scaling).

Note 1: Changing this parameter automatically brings Exe1 of initialization into execution.

6-3. Output group (Group 6)

Press the **GRP** key to call the OUTPUT screen (Group 6-0) and press the **SCRN** key to move to a screen in which a setting or a change is to be made. Use the **↔** key for selecting a parameter on the screen.

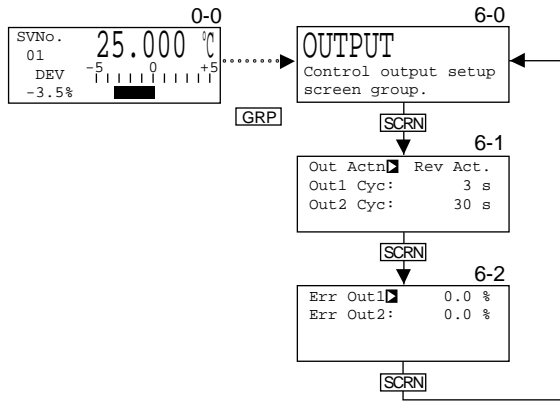

1) Set of output characteristics (direct action/reverse action) (Group 6-1)

Out Actn	Rev Act.
Out1 Cyc:	3 s
Out2 Cyc:	30 s

Setting range: Dir Act., Rev Act.
Initial value: Rev Act.

For control action characteristic of control output, Dir Act or Rev Act can be selected.

□ When the instrument is of one output type and MODE 0 or MODE 2 has been selected in 6-1. 4) Setting of mode:

Rev Act (reverse action): In this action, the higher the measured value (PV) than the set value (SV), the lower the output becomes. This action is generally used for heating control.

Dir Act (direct action): The higher the measured value (PV) than the set value (SV), the higher the output becomes. This action is generally used for cooling control.

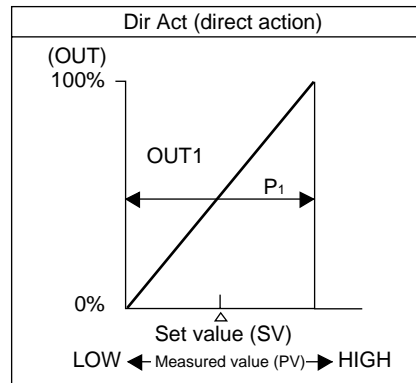
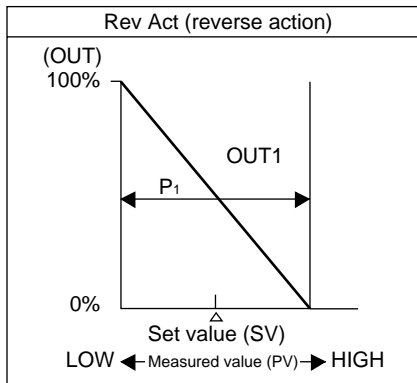

□ When the instrument is of the two-output type and MODE 1 or MODE 3 has been selected in 6-1. 4) Setting of mode:

Rev Act (reverse action): Output 1 is for heating control and Output 2 is for cooling control.

Dir Act (direct action): Both Output 1 and Output 2 are for heating control (2-stage heating).

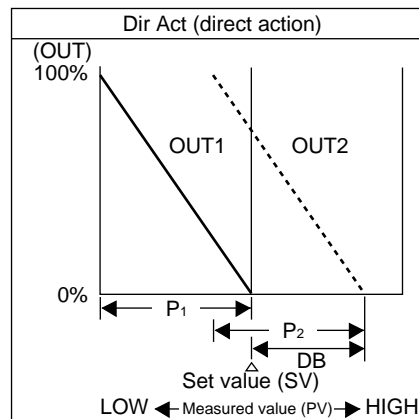
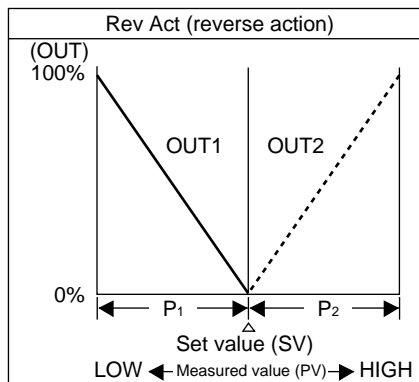

Note 1: For DB in the above diagram for Dir Act, refer to 6-6.7) Setting of dead band.

Note 2: To switch output characteristics is not possible during the execution of auto tuning (AT) or ramp control.

2) Setting of output cycle (Group 6-1)

(This setting is only for contact or SSR drive voltage output. This screen is not displayed in the case of voltage or current output.)

Out Actn:	Rev Act.
Out1 Cyc	3 s
Out2 Cyc	30 s

Setting range: 1~200 sec.

Initial value: In the case of SSR drive voltage output; 3 sec.

In the case of contact output; 30 sec.

Out Actn:	Rev Act.
Out1 Cyc	3 s
Out2 Cyc	30 s

For SSR drive voltage output, control is carried out through voltage pulse and for contact output through ON and OFF time ratio (duty) of relay contact. Cycle time, which is the basic cycle of the duty, can be set.

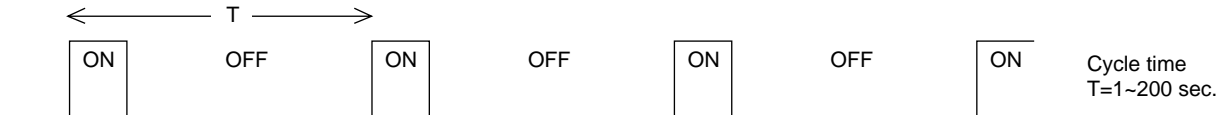

Note 1: Generally, cycle time is 20~30 sec. in the case of contact output, and 2~4 sec. in the case of SSR drive voltage output.

Note 2: If an excessively long time is set for cycle time in a control system with a short delay time, an adverse effect may be produced on the result of control.

Note 3: In the case of one output, the parameter Out 2 Cyc is not displayed on the screen.

Note 4: Output cycle cannot be set during the execution of auto tuning (AT) or ramp control.

3) Setting of output against Scale Over (Group 6-2)

Err Out1	0.0 %
Err Out2	0.0 %

Setting range: -5.0~105.0%

Initial value: 0.0%

Err Out1	0.0 %
Err Out2	0.0 %

Control output value for use when measured input value goes out of range can be set.

Note 1: In the case of one output, the parameter Err Out 2 is not displayed on the screen.

Note 2: Output against Scale Over cannot be set during the execution of auto tuning (AT).

Note 3: For contact and SSR drive voltage output, output against Scale Over automatically becomes 0% if P=OFF is set and ON-OFF control is selected in 6-6. 1) Setting of proportional band (P).

6-4. Option group (Group 5)

[This group has setting screens of optional functions (analog output, DI, heater break alarm and communication). These screens are not shown if the optional functions are not added in your instrument.]

Press the **GRP** key to call the OPTION screen (Group 5-0) and move to a screen in which setting or a change to be made by the use of the **SCRN** key. Use the  key for selecting a parameter on the screen.

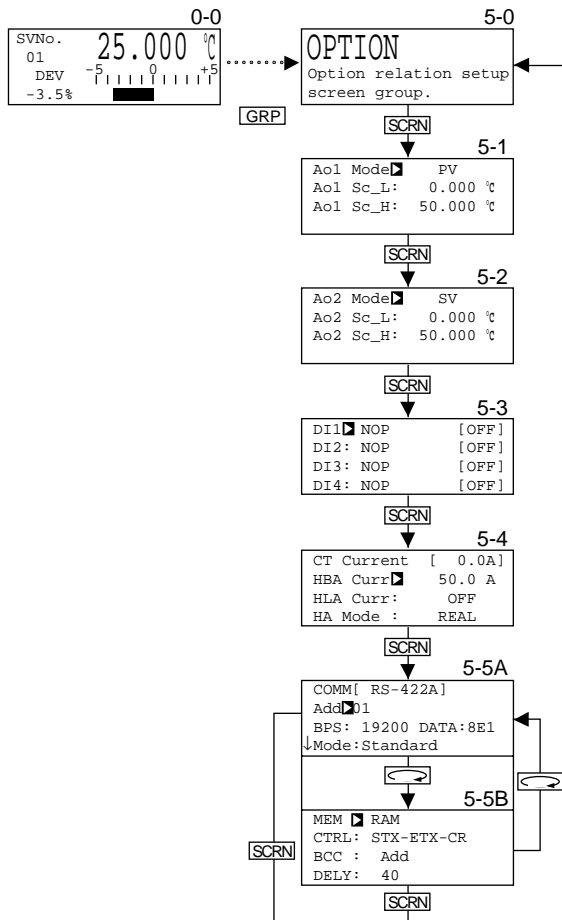

⊙ Matters Related to the Setting of Analog Output

1) Setting of analog output assignment (Group 5-1~2)

Ao1 Mode	PV
Ao1 Sc_L	0.000 °C
Ao1 Sc_H	50.000 °C

Measuring range: PV, SV, DEV, OUT1, OUT2
 Initial value: Analog output 1; PV
 Analog output 2; SV

Ao2 Mode	SV
Ao2 Sc_L	0.000 °C
Ao2 Sc_H	50.000 °C

The following can be assigned to analog outputs 1 and 2.

1. PV (measured value)
2. SV (set value)
3. DEV (deviation)
4. OUT 1 (control output 1)
5. OUT 2 (control output 2) [Only when the instrument is of the two output type]

Note 1: Analog output is produced even when STANBY has been selected in 6-8. 4) Execution/standby of control.

Note 2: In the instrument with one analog output, the Ao2 parameters are not shown on the screen.

2) Setting of analog output scaling (Group 5-1~2)

Ao1 Mode	PV
Ao1 Sc_L	0.000 °C
Ao1 Sc_H	50.000 °C

Ao2 Mode	SV
Ao2 Sc_L	0.000 °C
Ao2 Sc_H	50.000 °C

Setting range: Shown in the following table.
 Initial value: Shown in the following table.

Ao1 Mode	PV
Ao1 Sc_L	0.000 °C
Ao1 Sc_H	50.000 °C

Ao2 Mode	SV
Ao2 Sc_L	0.000 °C
Ao2 Sc_H	50.000 °C

Scaling of analog outputs 1 and 2 can be set.

Mode	Setting range	Initial value
PV	Within measuring range	Sc_L: Lower limit value of measuring range Sc_H: Higher limit value of measuring range
SV	Within measuring range	Sc_L: Lower limit value of measuring range Sc_H: Higher limit value of measuring range
DEV	-100.0 ~ 100.0%	Sc_L: -100.0% Sc_H: 100.0%
OUT1	0 ~ 100.0%	Sc_L: 0% Sc_H: 100.0%
OUT2	0 ~ 100.0%	Sc_L: 0% Sc_H: 100.0%

Both Sc_L < Sc_H and Sc_L > Sc_H are allowed only when Sc_L ≠ Sc_H.

Note 1: In the instrument with one analog output, the parameters Ao2 Sc_L and Ao2 Sc_H are not shown on the screen.

⊙ Matters Related to Setting of DI

3) Setting of DI assignment (Group 5-3)

DI1	<input checked="" type="checkbox"/> NOP	[OFF]
DI2	<input type="checkbox"/> NOP	[OFF]
DI3	<input type="checkbox"/> NOP	[OFF]
DI4	<input type="checkbox"/> NOP	[OFF]

Measuring range: 8 types as shown in the following table.
Initial value: DI1~4; NOP

For the purpose of carrying out external control by means of no-voltage contact signals externally, actions to be executed can be selected from the following 8 types and may be assigned to DI1 through 4:

Type	Description of action	When not in operation	Signal detection
Nop	No	-----	Level
Manual	Switching control output between auto and manual (ON: Manual)	AT, STB	Level
Remote	Setting REM SV/changing LOC SV setting (ON: REM SV set)	AT	Level
Auto Tune	Switching ON/OFF of AT (ON "edge": AT execution)	MAN, STB, RUN, REM	Edge
Stanby	Switching execution/pause of control (ON: pause)	None	Level
Dir Act.	Switching direct/reverse action of output characteristics (ON: Direct action)	AT, RUN	Level
Stop	Switching pause/restart of ramp control (ON: Pause in ramp control) (Only during execution of ramp control)	-----	Level
Direct	Switching ON/OFF of EV and DO output (ON: EV and DO outputs ON) (For details, see the explanation of "Direct" below.)	None	Level

Note 1: "When not in operation" :

When items shown in these columns are in operation, those shown in the "Description of action" columns are unable to be brought into execution by external control. The same applies to front key operation.

Note 2: Timing of detection of external control input signals :

Level input: Action continues while the contact is ON.

Edge input: When a contact is ON for 0.3 seconds or longer, its action starts, and continues after the contact is OFF. When it turns ON and remains for 0.3 seconds or longer again, the action is stopped.

Note 3: External control input may not be detected unless ON or OFF continues for 0.3 seconds or longer.

Note 4: Once items selected from the above 8 types are assigned to DIs, external control takes preference, that is, similar types of setting by front key operation are not possible.

Note 5: In case a similar type of action is assigned to two or more DIs, only the assignment to DI with the smallest number is valid. (For example, if Manual is assigned to DI1 and DI2, the assignment to DI2 is invalid.)

Note 6: Assignment of any action except Direct to a DI maintains the action even after the setting of the DI is released. (For example, if Stanby is assigned to DI1 and DI1 is set at Nop by external signal in this state, Stanby still works.)

* When you want to execute external control upon completion of setting, follow the instruction in Chapter 7 External Control Input/Output.

Notes on Direct Function:

DI or communication signals can be output to an Event and DO.

Fig. 1 shows relations between DIs and Events/DOs.

(For communication, refer to the separate Instruction Manual on Communication Interface.)

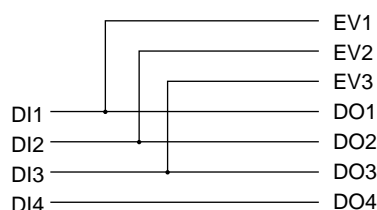

Requirements for use of direct function:

1. Assign Direct to a DI* to be input.
2. Assign Direct to EV* and DO* to be output.

* $\left\{ \begin{array}{l} \text{DI} \rightarrow 1\sim4 \\ \text{EV} \rightarrow 1\sim3 \\ \text{DO} \rightarrow 1\sim4 \end{array} \right.$

Fig. 1 Relations between DIs and Events/DOs

Example of use of Direct function:

If you want to output DI signal to EV3, as illustrated in Fig. 1, the DI input which can be output to EV3 is DI3.

- (1) Assign Direct to DI3. (See 6-4. 3) Setting of DI assignment.)
- (2) Assign Direct to EV3. (See 6-5. 1) Setting of event action and DO action mode.)
- (3) When input to DI3 is turned ON/OFF, EV3 output turns ON/OFF. (See Chapter 7 External Input/Output.)

⊙ Matters Related to Setting of Heater Break Alarm

4) Display of CT current (Group 5-4)

(Heater break alarm and heater loop alarm are usable when control output 1 is of contact (Y) or SSR drive voltage (P). They cannot be used if control output 1 is of current (I) or voltage (V).)

↓

CT Current [10.0A]	Display range: 0.0~54.9A
HBA Curr <input checked="" type="checkbox"/> OFF	
HLA Curr: OFF	
HA Mode : LOCK	

This screen shows current detected by the current detector (CT).

- When current detected by CT exceeds 55.0A, HB_HH is shown in the CT current display screen.
- When current detected by CT lowers to 0.0A or below, HB_LL is shown in the CT current display screen.
- In the event CT fails to detect any current, ---- is shown in the CT current indication screen.

Connection of current transformer (CT)

Pass a load wire through the hole of CT, which is provided as an attachment to the instrument. The wire from CT to temperature controller (SR253) has no polarity.

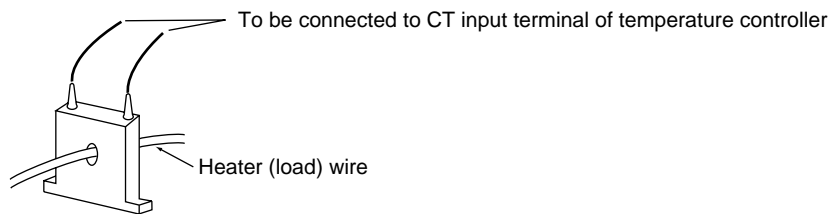

5) Setting of current value for the heater break alarm (Group 5-4)

CT Current [10.0A]	Setting range: OFF, 0.1~50.0A
HBA Curr <input checked="" type="checkbox"/> OFF	Initial value: OFF
HLA Curr: OFF	
HA Mode : LOCK	

CT detects the current level in the load wire while control output 1 is ON, and it judges as abnormality and outputs an alarm whenever a lower current level than set current value is detected. Even if control output 1 turns OFF, the alarm output is maintained.

Note 1: To use the heater break alarm, it is necessary to assign HBA to an event or external output in 6-5. 1) Setting of event action and DO action mode.

6) Setting of current value for the heater loop alarm (Group 5-4)

CT Current [10.0A]	Setting range: OFF, 0.1~50.0A
HBA Curr: OFF	Initial value: OFF
HLA Curr <input checked="" type="checkbox"/> OFF	
HA Mode : LOCK	

CT detects the current level in the load wire while control output 1 is OFF, and it judges as abnormality and outputs an alarm whenever a higher current level than set current value is detected. Even if it turns ON, the alarm output is maintained.

Note 1: To use the heater break alarm, it is necessary to assign HLA to an event or external output in 6-5. 1) Setting of event action and DO action mode.

7) Setting of the heater break/loop alarm mode (Group 5-4)

CT Current [10.0A]
HBA Curr:	OFF
HLA Curr:	OFF
HA Mode	<input checked="" type="checkbox"/> LOCK

Setting range: LOCK, REAL
Initial value: LOCK

You can select either the lock mode or the real mode for alarm output.

Lock mode (LOCK): Once alarm is output, the alarm output is locked (fixed) and the alarm keeps being output even if the CT current level returns to normal. The alarm output cannot be turned off unless OFF is set for alarm current value or power is turned off.
Real mode (REAL): If CT current level returns to normal while alarm is being output, the alarm output will automatically turn off.

⊙ Matters Related to Setting for Communication Environment

8) Communication-related setting (Group 5-5 A/B)

COMM[RS-422A]
Add <input checked="" type="checkbox"/> 01
BPS: 19200 DATA: 8E1
↓ Mode: Standard

MEM <input checked="" type="checkbox"/> RAM
CTRL: STX-ETX-CR
BCC : Add
DELY: 40

For communication-related setting, see the separate Instruction Manual on Communication Interface.

6-5. Event/DO group (Group 4)

(The screens of this group are not displayed when EV and DO are not set as optional on the screens concerned.)

* On the description of each setting, explanation is made on EV but this explanation applies to DO as well.

Press the **GRP** key to call the EVENT/DO screen (Group 4-0) and move to a screen in which setting or a change is to be made by the use of the **SCRN** key. Use the  key for selecting a parameter on the screen.

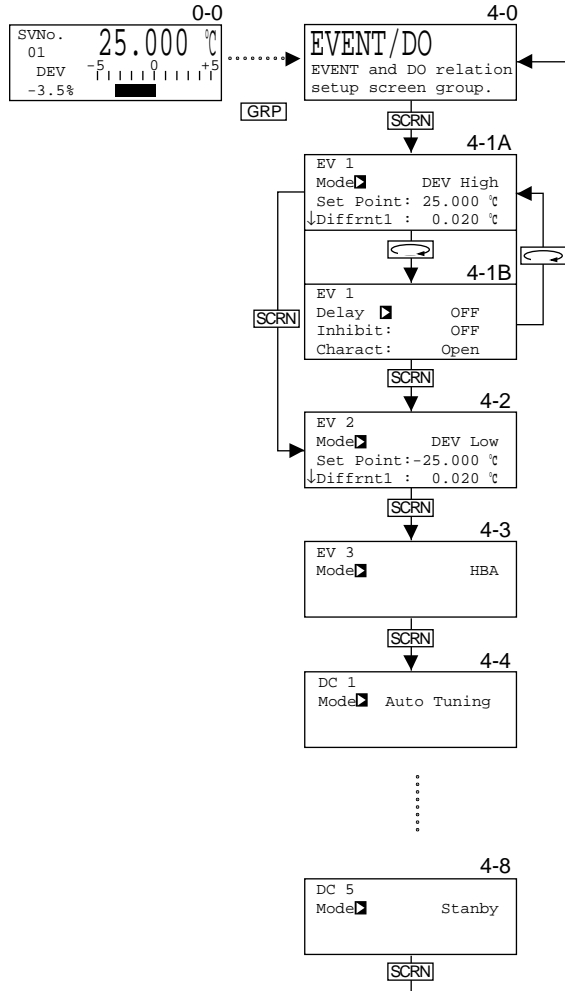

1) Setting of event action and DO action mode (Group 4-1A~4-8A)

```

EV 1
Mode [ ] DEV High
Set Point: 25.000 °C
↓Diffrent1 : 0.020 °C
    
```

⋮

```

DO 5
Mode [ ] Stanby
    
```

Setting range: 19 types listed below (Nevertheless, HBA and HLA can be set only when the instrument has the optional function of heater break alarm.

Initial value:	Type of event	EV 1	EV 2	EV 3	DO 1	DO 2	DO 3	DO 4	DO 5
	Initial value	DEV High	DEV Low	Scale Over HBA (When HB is equipped)	Auto Tuning	Manual	Remote	RUN	Stanby

In the event action and DO action mode, there are the following 19 events which are possible to monitor. In this screen, events selected from them are assigned to event and external outputs.

□ Types of Events

- (1) DEV High : Higher limit deviation value action
- (2) DEV Low : Lower limit deviation value action
- (3) DEV Outside : Action outside higher/lower limits of deviation
- (4) DEV Inside : Action inside higher/lower limits of deviation
- (5) PV High : PV higher limit absolute value action
- (6) PV Low : PV lower limit absolute value action
- (7) SV High : SV higher limit absolute value action
- (8) SV Low : SV lower limit absolute value action
- (9) Auto Tuning : While auto tuning in action ON
- (10) Manual : While manual control in action ON
- (11) Remote : While remote control in action ON
- (12) Run : While ramp control in action ON
- (13) Stanby : While control action is off ON
- (14) Scale Over : When PV and REM get out of range ON
- (15) PV Scale Over : When PV gets out of range ON
- (16) REM Scale Over : When REM gets out of range ON
- (17) Direct : During direct output ON
- (18) HBA : During output of heater break alarm ON (option)
- (19) HLA : During output of heater loop alarm ON (option)

See the diagrams below.

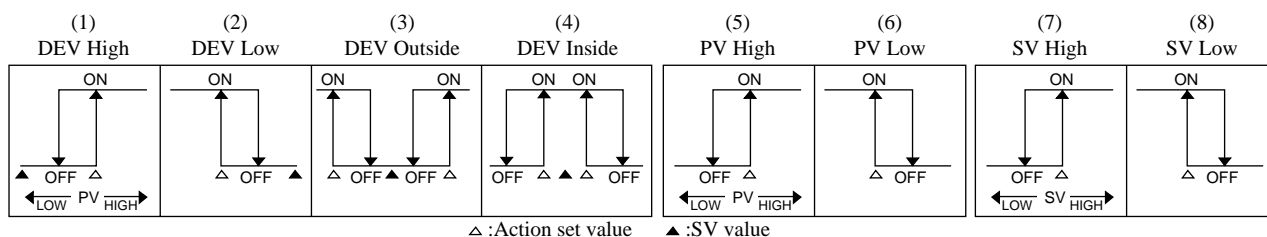

Note 1: In the above diagrams, ON and OFF mean that the respective actions are activated or not. Nevertheless, the back output differs depending on Open or Close selected in 6-5. 6) Setting of output characteristics.

Note 2: In case a type of event is changed, parameters of set action point (Set Point), action hysteresis (Diffrent1), delay time (Delay), inhibit action (Inhibit), and output characteristics (Charact) are initialized.

2) Setting of action point (Group 4-1A~4-8A)

(The setting is required only when any of the event types (1)~(8) is set for event action and DO action modes. When any of the event types (9)~(19) is set, these screens are not displayed.)

EV 1
Mode: DEV High
Set Point: 25.000 °C
↓Diffrent1 : 0.020 °C

Setting range: DEV High ; 0~25000 unit	Initial value: DEV High ; 25000 unit
DEV Low ; -25000~0 unit	DEV Low ; -25000 unit
DEV Outside ; 0~25000 unit	DEV Outside ; 25000 unit
DEV Inside ; 0~25000 unit	DEV Inside ; 25000 unit
PV High ; Within measuring range	PV High ; Higher limit value of measuring range
PV Low ; Within measuring range	PV Low ; Lower limit value of measuring range
SV High ; Within measuring range	SV High ; Higher limit value of measuring range
SV Low ; Within measuring range	SV Low ; Lower limit value of measuring range

In this screen, action points of event output and external output are set.



In the case of DEV Outside or DEV Inside, inputting a positive deviation value and setting a positive action point automatically sets a negative action point to form a range of action points.

Example:
 When "SV value 50°C
 Mode: DEV Outside
 Set Point: 20.00°C" is set,
 a positive action point and a negative action point are decided and the action point range as shown in the right diagram is formed.

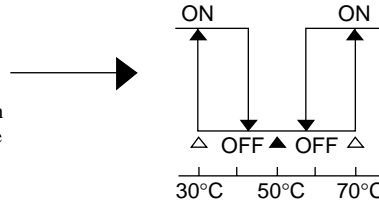

3) Setting of action hysteresis (Group 4-1A~4-8A)

(The setting is required only when any of the event types (1)~(8) is set for event action and DO action. When any of the event types (9)~(19) is set, these screens are not displayed.)

EV 1
Mode: DEV High
Set Point: 25.000 °C
↓Diffrent1 : 0.020 °C

Setting range: 1~9999 unit
 Initial value: 20 unit

Setting an action hysteresis between ON action and OFF action can avoid chattering and the like and ensure stable event action.

Example: When PV is Low

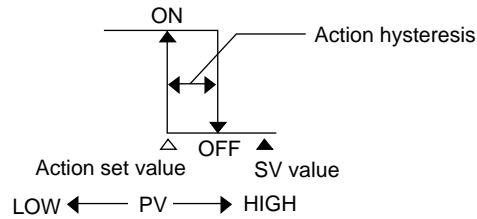

4) Setting of delay time (Group 4-1B~4-8B)

(The setting is required only when any of the event types (1)~(8) is set for event action and DO action modes. When any of the event types (9)~(19) is set, these screens are not displayed.)

EV 1	
Delay	OFF
Inhibit:	OFF
Character:	Open

Setting range: OFF, 1~9999 unit
Initial value: OFF

Once a delay time is set, when a factor requiring output of ON signal to event and DO outputs arises, ON signal is output not immediately but only after a certain time (delay time) elapses.

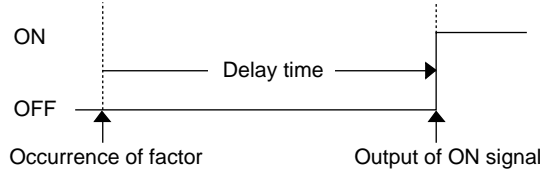

Note 1: In case the factor for signal output disappears within the delay time, the delay time is cleared without outputting ON signal. If the factor arises again, the time count is redone from the beginning.

Note 2: When OFF is set for delay time, signal is output simultaneously with the occurrence of a factor for ON signal output.

Note 3: Delay time can be changed within delay time after occurrence of a factor for ON signal output. Nevertheless, delay time is counted from the occurrence of the output factor, not from the time at which the change is made. (See the following examples.)

Example 1: Delay time set at 15S.
Changed to 10S when 5S has elapsed after the occurrence of factor.

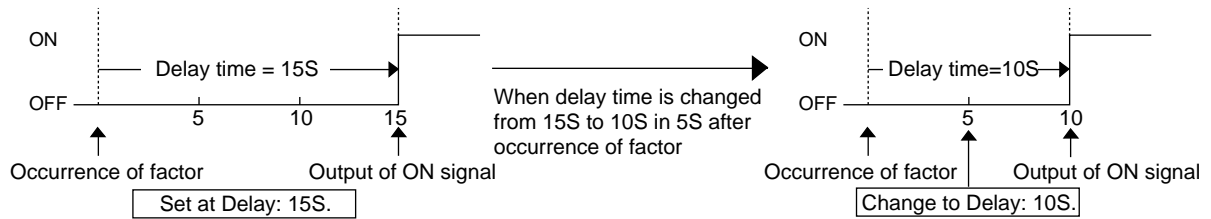

Example 2: Delay time set at 15S.
Changed to 20S when 5S has elapsed after the occurrence of factor.

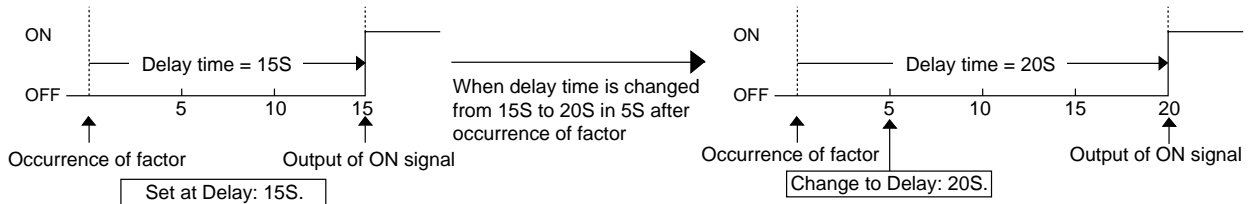

5) Setting of inhibit action (Group 4-1B~4-8B)

(The setting is required only when any of the event types (1)~(8) is set for event action and DO action modes. When any of the event types (9)~(19) is set, these screens are not displayed.)

EV 1	
Delay :	OFF
Inhibit <input checked="" type="checkbox"/>	OFF
Charact:	Open

Setting range: ON, OFF
Initial value: OFF

When you set inhibit action, select ON or OFF by taking the event action for Scale Over as well as inhibit action.

- Inhibit: ON → With inhibit action

Note 1: The event action turns ON when Scale Over occurs on the event setting side.

- Inhibit: OFF → Without inhibit action

Note 2: Event action turns OFF when Scale Over occurs on the event setting side.

Note 3: If you want to output alarm when Scale Over occurs after setting Inhibit: OFF, assign Scale Over to other event or DO.

On Inhibit Action:

It is possible to keep ON signal waiting if PV value is in the ON range of event action when power is applied or STANBY is released, and to output ON signal when the PV value returns to the OFF range of event action and then enters the ON range of event action.

Example: PV Low has been assigned to EV1 and Inhibit:ON has been set:

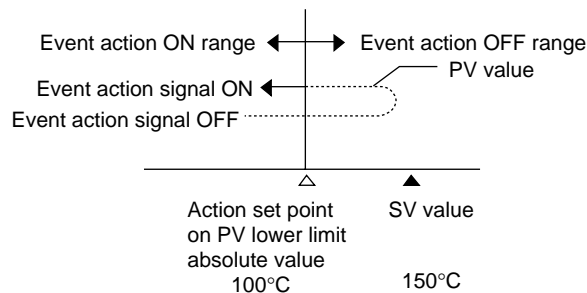

Note 4: Inhibit action gets on when power is applied or STANBY is released, and remains off at any time other than the above.

Note 5: If PV value is in the ON range of event action when power is applied or STANBY is released and setting of inhibit action is changed to Inhibit:OFF, the inhibit action is canceled immediately and ON signal is output.

Note 6: If PV value is in the OFF range of event action when power is applied or STANBY is released, inhibit action is canceled.

6) Setting of output characteristics (Group 4-1B~4-8B)

(The setting is required only when any of the event types (1)~(8) are set in event action and DO action modes. When any of the event types (9)~(19) are set, these screens are not displayed.)

EV 1	
Delay :	OFF
Inhibit:	OFF
Charact <input checked="" type="checkbox"/>	Open

Setting range: Open, Close
Initial value: Open

Output characteristics of event and DO outputs can be selected between Open (Normal open) and Close (Normal close).

Open (Normal open): When event is out of action, the contact remains open. When DO is out of action, the output transistor is in an inactive state.

Close (Normal close): When event is out of action, the contact remains closed. When DO is out of action, output transistor is in an active state.

6-6. PID group (Group 3)

(The configuration of this group differs depending on whether the instrument has one output or two outputs as control output.)

As this instrument can work with multi-PIDs corresponding to multi-SVs, PID constants can be registered at PID Nos. corresponding to SV Nos. When the Auto Tuning (AT) function is used, PID values are set automatically. You need not set them. (Refer to 6-8. 1) Execution/stop of auto tuning.) Depending on the object of control, however, it may be required to correct PID values even when auto tuning is executed.

Press the **GRP** key to call the PID screen (Group 3-0). Next, press the **SCRN** key, and the screen with the PID No. currently being used is displayed. (This is only when the PID screen was called from any of the other screen groups. If you press the **GRP** key in any of the PID group screens and press the **SCRN** key, the screen of PID No.1 is displayed.) Then, every time the **SCRN** key is pressed, the PID No. changes successively. Stop pressing when the screen of the PID No. to be set or changed is displayed. Use the **↔** key for selecting a parameter on the screen.

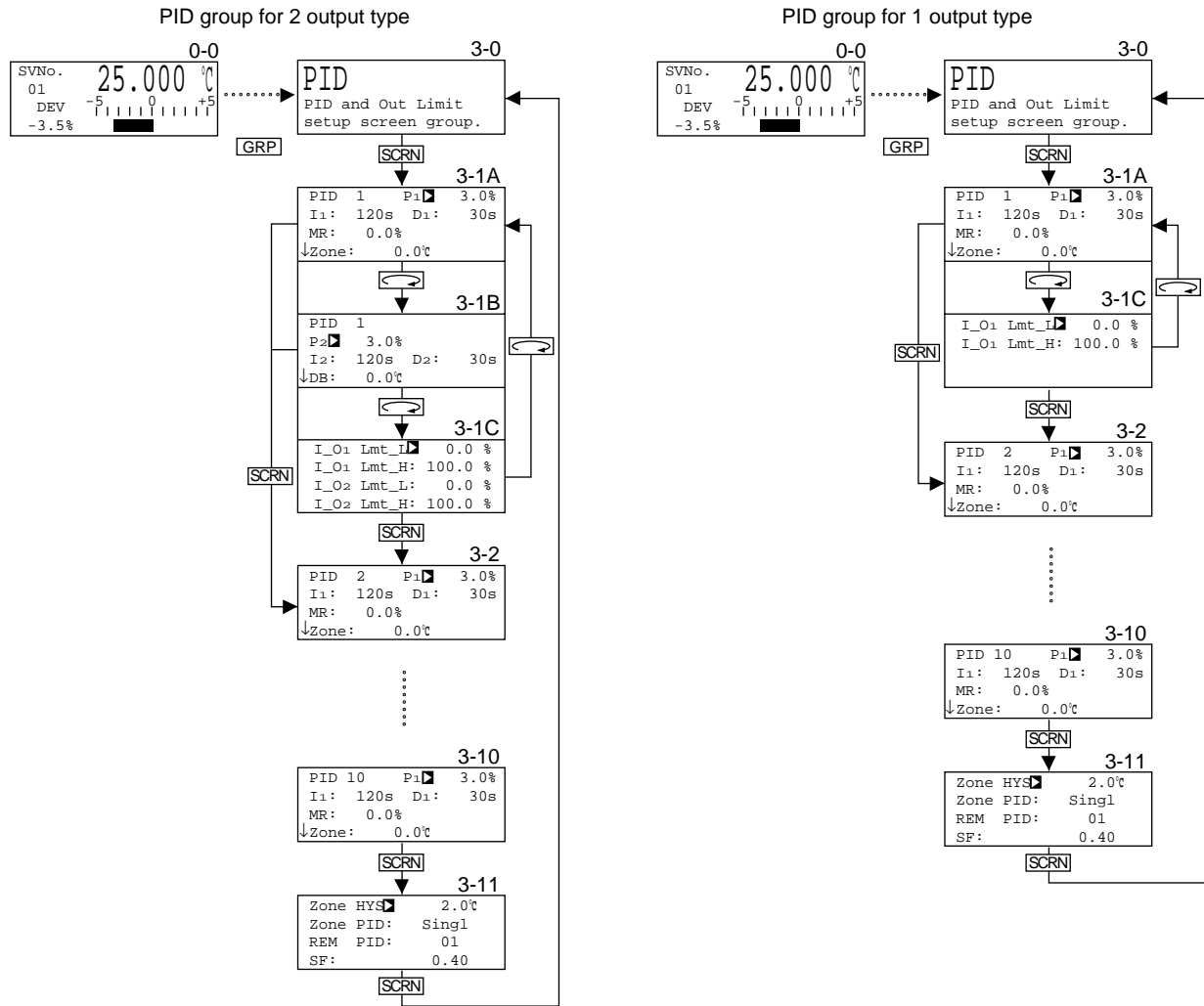

P₁, I₁, D₁: PID of output 1
P₂, I₂, D₂: PID of output 2

1) Setting of proportional band (P) (Group 3-1A~)

PID	1	P1	3.0%
I1	120s	D1	30s
MR	0.0%		
↓Zone	0.0°C		

Setting range: OFF, 0.1~999.9%
Initial value: 3.0%

A rate (%) of a change in control output to measuring range is set. Control output changes in proportion to difference (deviation) between measured (PV) value and set (SV) value.

The wider the proportional band, the smaller the change in control output. The narrower the proportional band, the larger the control output. Nevertheless, too narrow a proportional band causes control to oscillate (hunting), with the control result resembling ON-OFF action. When OFF is set for proportional band, ON-OFF control is carried out.

Note 1: When OFF is selected for P, auto tuning cannot be executed.

2) Setting of action hysteresis (DF) (Group 3-1A~)

PID	1	P1	OFF
DF1	2.0°C		
↓Zone	0.0°C		

Setting range: 1~9999 unit
Initial value: 20 unit

Setting P=0 (OFF) starts ON-OFF control. Setting action hysteresis (DF) between ON and OFF at that time works to avoid chattering or the like and to stabilize control.

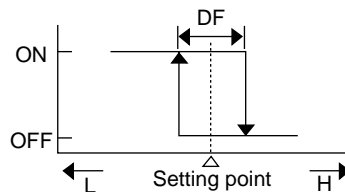

3) Setting of integral time (I) (Group 3-1A~)

PID	1	P1	3.0%
I1	120s	D1	30s
MR	0.0%		
↓Zone	0.0°C		

Setting range: OFF, 1~6000 sec.
Initial value: 120 sec.

This is the function to correct offset (constant deviation) caused by proportional action. The longer the integral time, the weaker the correcting action and vice versa. Nevertheless, too short an integral time causes integral hunting, with the control results showing oscillation.

4) Setting of differential time (D) (Group 3-1A~)

PID	1	P1	3.0%
I1	120s	D1	30s
MR	0.0%		
↓Zone	0.0°C		

Setting range: OFF, 1~3600 sec.
Initial value: 30 sec.

A change in control output is estimated; overshoot due to integration is suppressed; and stability of control is improved.

The shorter the differential time, the weaker the differential action and vice versa. If it is too long, however, the control result may oscillate.

Note 1: Even when auto tuning is executed with D=OFF, D=OFF remains unchanged.

5) Setting of manual reset (MR) (Group 3-1A~)

PID	1	P1:	3.0%
I1:	OFF	D1:	30s
MR	0.0%		
↓Zone:	0.0°C		

Setting range: -50.0~+50.0%
 Initial value: 0.0 % for 1 output type
 -50.0 % for 2 output type

This is the function to make correction manually while watching the result of controlling offset produced by carrying out control action with P or P+D when OFF is set for I (integral time). If a value is set on the + side, the control result moves in the plus direction and it moves in the minus direction if a value is set on the - side. The amount of movement is in proportion to numerical value.

Note 1: Even when auto tuning is executed with I=OFF, I=OFF remains unchanged and the value of Manual Reset (MR) is automatically calculated and setting is made.

6) Setting of zone (Group 3-1A~)

PID	1	P1:	3.0%
I1:	120s	D1:	30s
MR:	0.0%		
↓Zone	0.0°C		

Setting range: Within measuring range
 Initial value: 0 unit

In this screen a zone required for the zone PID function is set for each PID No.

Zone PID function ... When set value (SV) exceeds zones as illustrated below, this function automatically switches PID Nos. to be executed.

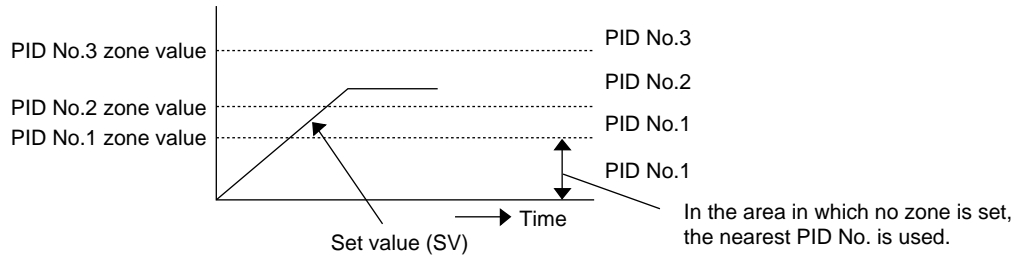

Note 1: When the same zone value is set for two or more PID Nos., the smallest PID No. is executed.

Note 2: To use the zone PID function, 6-6. 9) Setting of zone hysteresis and 6-6. 10) Setting of zone PID mode should be carried out in addition to setting of zone.

7) Setting of dead band (Group 3-1B~)

(This setting is only for the two output type. The screen is not displayed in the case of one output.)

PID	1
P2:	3.0%
I2:	120s D2: 30s
↓DB	0.0°C

Setting range: -20000~20000 unit
Initial value: 0 unit

To carry out two output control, by taking characteristics of the object of control and the energy-saving effect into account, action range of control output 2 can be set as shown in the following action characteristic diagrams.

Example: When MODE 1 or MODE 3 is selected in 6-1. 4) Setting of mode and Rev Act in 6-3. 1) Setting of output characteristics:

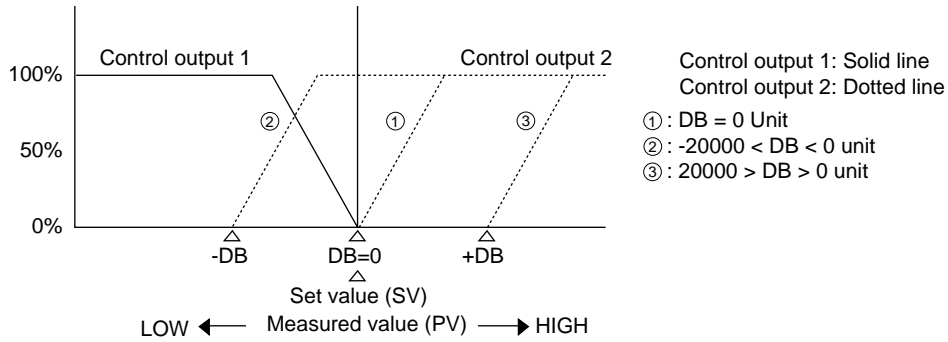

Example: When MODE 1 or MODE 3 is selected in 6-1. 4) Setting of mode and Dir Act in 6-3. 1) Setting of output characteristics:

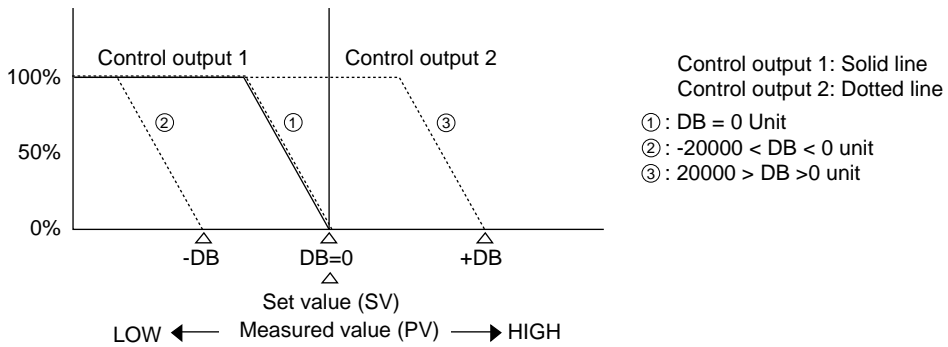

8) Setting of output limit (Group 3-1C~)

1_O1	Lmt_L	0.0 %
1_O1	Lmt_H	100.0 %
1_O2	Lmt_L	0.0 %
1_O2	Lmt_H	100.0 %

Setting range: Lower limit value; -5.0~104.9%
Higher limit value; -4.9~105.0%
(Lower limit value < Higher limit value, though)

Initial value: Lower limit value; 0%
Higher limit value; 100%

1_O1	Lmt_L	0.0 %
1_O1	Lmt_H	100.0 %
1_O2	Lmt_L	0.0 %
1_O2	Lmt_H	100.0 %

In this screen, lower and higher limits of control output values corresponding to PID Nos. are set.

Note 1: In case the instrument is of the one output type, parameters related to two outputs are not shown.

Note 2: For Contact and SSR drive voltage output, output limits become invalid in case OFF is selected in 6-6. 1) Setting of proportional band (P) for ON-OFF control.

9) Setting of zone hysteresis (Group 3-11)

Zone HYS	2.0℃
Zone PID	Singl
REM PID	01
SF	0.40

Setting range: 0~10000 unit
Initial value: 20 unit

For set zone values, the following hysteresis can be set. This hysteresis applies to all the set zone values, however.

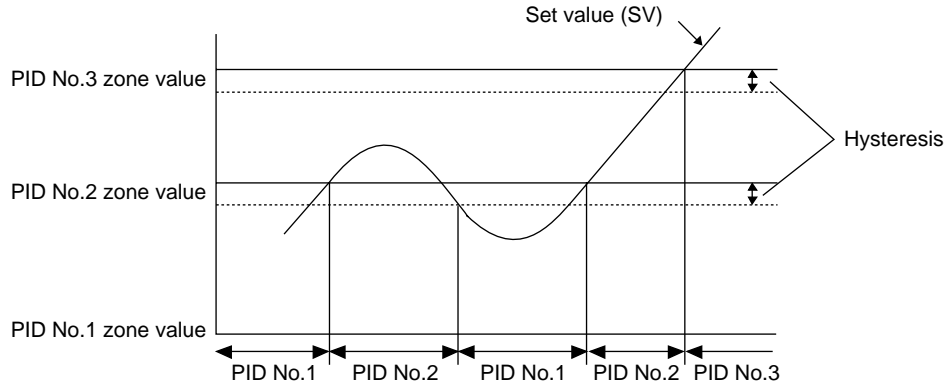

10) Setting of zone PID mode (Group 3-11)

Zone HYS	2.0℃
Zone PID	Singl
REM PID	01
SF	0.40

Setting range: Singl, Zone
Initial value: Singl

The PID function mode can be selected between Zone and Singl.

Zone.....Using the zone PID function (SV No. remains unaffected.)

SinglNot using the zone PID function (PID No. is switched correspondingly to SV No.)

11) Setting of remote PID No. (Group 3-11)

Zone HYS	2.0℃
Zone PID	Singl
REM PID	01
SF	0.40

Setting range: 1~10
Initial value: 1

Remote PID corresponding to remote SV can be changed from PID Nos. 1 through 10. The setting does not work, however, in case PID function is being used.

12) Setting of target value function (Group 3-11)

Zone HYS	2.0℃
Zone PID	Singl
REM PID	01
SF	0.40

Setting range: 0.00~1.00
Initial value: 0.40

If set value is subjected to overshooting or undershooting during PID control, it is corrected by this function with reference to control results.

SF = 0.00 : Ordinary PID operation is carried out.

SF → Small : Corrective function against overshooting works weakly.

SF → Large : Corrective function against overshooting works strongly.

Note 1: Setting of a target value function is valid only when an integral action has been selected (PI or PID action).

6-7. SV/Remote/Ramp group (Group 2)

Press the **GRP** key to call SV screen (Group 2-0). Then press the **SCRN** key, and the screen of SV No. currently in use is displayed. (This functions only when the screen 2-0 has been called from another group. In case the **GRP** key is pressed in the same group to return to the initial screen of the group and the **SCRN** key is pressed, the screen of SV No.1 is displayed.) The SV No. changes successively every time the **SCRN** key is pressed, thus moving to the screen of SV No. to be set or changed. Use the  key for selecting a parameter in the screen.

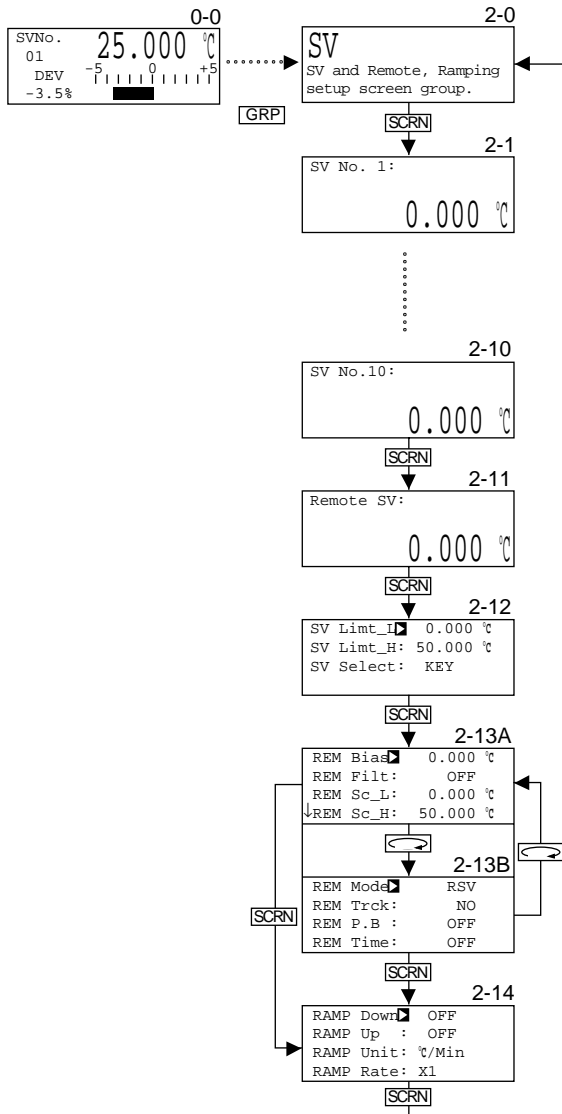

⊙ Matters Related to SV Setting

1) Setting of set value (SV) (Group 2-1~)

SV No. 1:	0.000 °C
-----------	----------

Setting range: Within SV limits
Initial value: 0 unit

Ten SV values maximum can be set suitably for your intended use.

Note 1: In case Mode 0 or 1 is selected in 6-1. 4) Setting of mode, only two items, SV No.1 and Remote SV, are shown.

Note 2: Remote SV is only for monitoring; it cannot be set or changed by front key operation.

Note 3: To change SV value and to switch SV No. is not possible during execution of auto tuning (AT).

2) Setting of SV limits (Group 2-12)

SV Limt_L	0.000 °C
SV Limt_H	50.000 °C
SV Select	KEY

Setting range: Within measuring range but SV Limt_L < SV Limit_H
 Initial value: SV Limt_L; Lower limit value of measuring range
 SV Limt_H; Higher limit value of measuring range

SV Limt_L	0.000 °C
SV Limt_H	50.000 °C
SV Select	KEY

Higher limit (SV Limt_H) and lower limit (SV Limt_L) of setting range for set value (SV) can be set.

Note 1: Remote SV value is also subject to SV limits.

3) Setting of selection/switch of multi-SV No. (Group 2-12)

(This screen is not displayed unless external input/output control signal (DI/DO) is added. When MODE 0 or MODE 1 has been selected in 6-1. 4) Setting of mode, this screen is not displayed either.)

SV Limt_L	0.000 °C
SV Limt_H	50.000 °C
SV Select	KEY

Setting range: KEY, EXT
 Initial value: KEY

It can be selected whether multi-SV No. is selected by means of front key (KEY) or externally (EXT).

- When SV Select: KEY is set
 Select SV No. by using front key in the monitor group screen (Group 0-0).
- When SV Select: EXT is set (ESV lamp in front panel lights.)
 Select SV No. externally.

⊙ Matters Related to Remote Setting

4) Setting of remote bias (Group 2-13A)

REM Bias	0.000 °C
REM Filt	OFF
REM Sc_L	0.000 °C
↓REM Sc_H	50.000 °C

Setting range: -9999~9999 unit
 Initial value: 0 unit

Remote bias corrects error in remote set input value.

5) Setting of remote filter (Group 2-13A)

REM Bias	0.000 °C
REM Filt	OFF
REM Sc_L	0.000 °C
↓REM Sc_H	50.000 °C

Setting range: OFF, 1~300
 Initial value: OFF

If remote input has noise, unstable remote SV indication may produce an adverse effect on control result. A remote filter is used to reduce such effect and stabilize control.

Filter operation is carried by linear delay operation.

$$\text{Time constant T (sec.)} = \text{set value} \times \text{sampling cycle of remote input (sec.)}$$

From the above equation, $T = 300 \times 1/3 = 100$ sec.

Thus, remote filter with a time constant of 100 sec. maximum is applied. Accordingly, the larger the set value, the longer the time constant and the more effectively noise can be removed.

It should be noted, however, that too large a time constant may have a detrimental effect on the result of control in highly responsive control system.

6) Setting of remote scale (Group 2-13A)

REM Bias:	0.000 °C
REM Filt:	OFF
REM Sc_L:	0.000 °C
↓REM Sc_H:	50.000 °C

Setting range: Within measuring range (RSV)
 0.00~100.00% (CTRL)
 but REM Sc_L ≠ REM Sc_H
 Initial value: REM Sc_L; Lower limit of measuring range (RSV)
 0.00% (CTRL)
 REM Sc_H; Higher limit of measuring range (RSV)
 100.00% (CTRL)

REM Bias:	0.000 °C
REM Filt:	OFF
REM Sc_L:	0.000 °C
↓REM Sc_H:	50.000 °C

Setting range of SV for remote set input can be set.

Note 1: For setting of remote scale when REM Mode:CTRL has been set, see 6-7. 7) Setting of remote mode.

7) Setting of remote mode (Group 2-13B)

REM Mode:	RSV
REM Trck:	NO
REM P.B :	OFF
REM Time:	OFF

Setting range: RSV, CTRL
 Initial value: RSV

There are the following two remote modes:

- RSV mode: Remote input is used as general RSV (remote SV) input.
- CTRL mode: Remote input is used as external control input.
 In this mode, the following parameters need to be set:
 Remote scale (REM Sc_L, Sc_H)
 Remote proportional coefficient (REM P.B)
 Remote linear delay time (REM Time)

On External Control (CTRL mode):

In the event there is a disturbance factor in the control system and the disturbance can be identified and be reflected in the control system beforehand, more accurate control can be achieved by taking the factor as external control input in control operation. This is the object of this function. (External control operates as follows:)

Rough block diagram

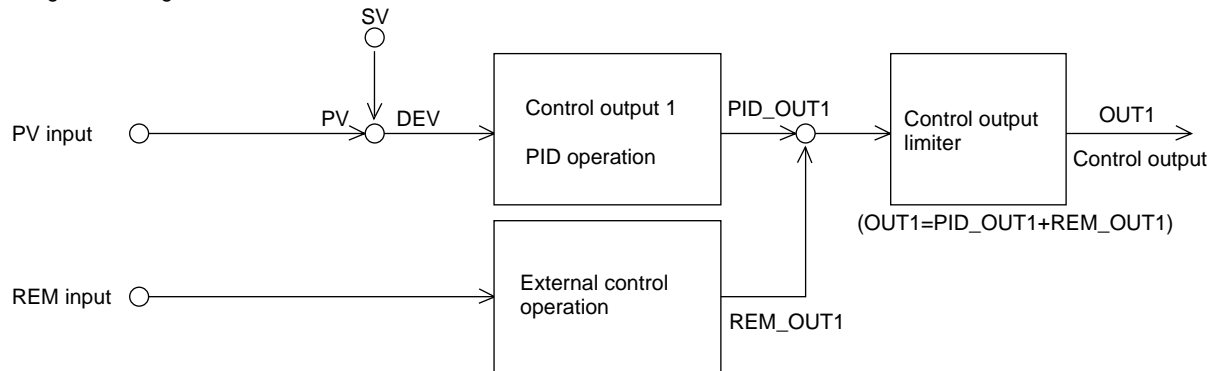

Note 1: This external control works only for control output 1.

On External Control Operation

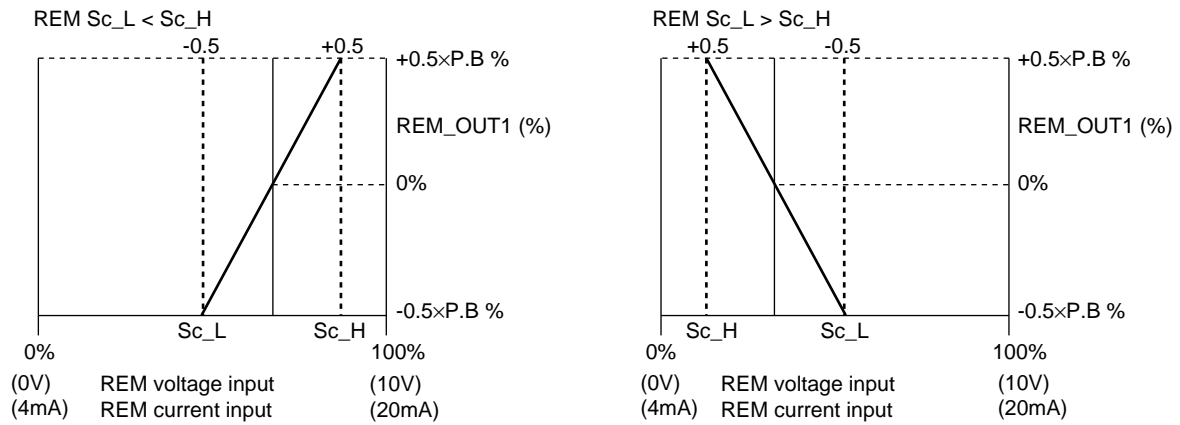

Note 1: For P.B, see 6-7. 9) Setting of remote proportional coefficient.

$$\text{REM_OUT1} = \{ \text{REM input value} - (\text{Sc_H} + \text{Sc_L}) / 2 \} / (\text{Sc_H} - \text{Sc_L}) \times \text{P.B} [\%]$$

Here, linear delay operation on the above REM_OUT1 is carried out by the use of REM Time. Note that REM_OUT1 is restricted as follows:

$$-100.0\% \leq \text{REM_OUT1} \leq +100.0\%$$

Note 2: For REM Time, see 6-7. 10) Setting of remote linear delay time.

Note 3: External control operation is not carried out when remote input value goes over scale.

Note 4: When REM has been assigned to DI input, external control operation is carried out as follows:

If DI to which REM has been assigned is OFF → External control operation is not carried out.

If DI to which REM has been assigned is ON → External control operation is carried out.

Note 5: In the event external control operation is started before the control system and REM input become stable, control action may lack stability. We recommend you to begin external control operation only after the control system and REM input are somewhat stabilized.

8) Setting of remote tracking (Group 2-13A)

REM Mode :	RSV
REM Trck <input checked="" type="checkbox"/>	NO
REM P.B :	OFF
REM Time :	OFF

Setting range: YES, NO
 Initial value: NO

Remote SV value can be copied in SV value of any local SV No.

In case REM Trck: YES

When KEY has been selected in 6-7. 3) Setting of selection/switch of multi-SV No.

Upon moving from remote SV No. to desired local SV No. by key operation, remote SV value is copied in SV value of the local SV No. Notwithstanding, if Remote is assigned in 6-4. 3) Setting of DI assignment and REM SV/LOC SV has been switched by means of external contact signal, the remote SV value is copied in SV value of SV No.1.

When EXT has been selected in 6-7. 3) Setting of selection/switch of multi-SV No.

Upon moving from remote SV No. to local SV No. selected by external switch by means of external control signal, remote SV value is copied in SV value of the local SV No.

In case REM Trck: NO

Remote tracking does not function.

Note 1: In case remote SV values goes over Scale, remote tracking does not function.

9) Setting of remote proportional coefficient (Group 2-13A)
 (This parameter is valid only when REM Mode:CTRL.)

REM Mode:	RSV	Setting range: OFF, 0.1~999.9%
REM Trck:	NO	Initial value: OFF
REM P.B <input checked="" type="checkbox"/>	OFF	
REM Time:	OFF	

Remote proportional coefficient (REM P.B) is the parameter for setting a percentage at which a value whose range is specified in Remote Scale is output to REM_OUT1.

The larger REM P.B, the larger REM_OUT1 value.
 The smaller REM P.B, the smaller REM_OUT1 value.

Note 1: When REM P.B=OFF, external control operation is not carried out.

10) Setting of remote linear delay time (Group 2-13A)
 (This parameter is valid only when REM Mode:CTRL.)

REM Mode:	RSV	Setting range: 1~9999, control cycle (0.2 sec.)
REM Trck:	NO	Initial value: OFF
REM P.B :	OFF	
REM Time <input checked="" type="checkbox"/>	OFF	

Remote linear delay time (REM Time) is the parameter used to set the length of time to be taken for reflecting a change in remote input in REM_OUT1 output.

The longer REM time, the more slowly a change in remote is reflected in REM_OUT1.

Note 1: If REM Time=OFF, a change in remote input is reflected directly in REM_OUT1.

Matters Related to Ramp Setting

(This setting is used only when Mode 2 or 3 has been set in 6-1. 4) Setting of mode. If Mode 1 or 4 has been set, this screen is not displayed.)

What is "ramp control"?
It is the function that when set value (SV value) is changed, it undergoes the change gradually according to set time and amount of change lest the load be changed abruptly.

11) Setting of ramp value (Group 2-14)

RAMP Down <input checked="" type="checkbox"/>	OFF	Setting range: RAMP_Down ; OFF, 1~9999
RAMP Up :	OFF	RAMP_Up ; OFF, 1~9999
RAMP Unit:	°/Min	Initial value: RAMP_Down ; OFF
RAMP Rate:	X1	RAMP_Up ; OFF

RAMP Down:	OFF
RAMP Up <input checked="" type="checkbox"/>	OFF
RAMP Unit:	°/Min
RAMP Rate:	X1

In this screen downward ramp value (RAMP_Down) and upward ramp value (RAMP_Up) are set.

Note 1: Whether to use downward ramp value (RAMP_Down) or upward ramp value (RAMP_Up) during execution of ramp control is automatically selected by the instrument.

Note 2: It is possible to change downward ramp value (RAMP_Down) or upward ramp value (RAMP_Up) during execution of ramp control. When changed, ramp control is carried out immediately with new values.

Note 3: If downward ramp value (RAMP_Down) or upward ramp value (RAMP_Up) is turned OFF during execution of ramp control, ramp control stops and the SV value of the targeted SV No. serves as SV value.

12) Setting of ramp unit (Group 2-14)

RAMP Down:	OFF
RAMP Up :	OFF
RAMP Unit:	°/Min
RAMP Rate:	X1

Setting range: Unit/Sec., Unit/Min.
Initial value: Unit/Min.

In this screen, second (Sec.) or minute (Min.) is selected as the unit of the rate of change.

Note 1: The unit of ramp time can be changed during execution of ramp control. When changed, ramp control is carried out immediately on the new unit.

13) Setting of ramp rate (Group 2-14)

RAMP Down:	OFF
RAMP Up :	OFF
RAMP Unit:	°/Min
RAMP Rate:	X1

Setting range: × 1, × 0.1
Initial value: × 1

For the position of decimal point of PV display on set unit, × 1 or × 0.1 can be selected.

Note 1: Ramp rate can be changed during execution of ramp control. When changed, ramp control is carried out immediately at the new ramp rate.



How to Execute Ramp Control

- Conditions for execution (common to front key input and external input)
 - (1) AT is not in execution.
 - (2) STANBY is not on.
 - (3) RAMP_Down or RAMP_Up is not OFF.
 - (4) Neither Mode 0 nor Mode 1 not selected in 6-1. 4) Setting of mode.

Note 1: Ramp control is not executed by moving from local SV No. to remote SV No.

Note 2: When YES has been selected in 6-7. 8) Setting of remote tracking, ramp control is not executed by moving from remote SV No. to local SV No.

Note 3: If power turns OFF during execution of ramp control, ramp control is stopped and the SV value of targeted SV No. serves as SV value.

To begin with, press the **DISP** key to call the initial screen (Group 0-0) of the monitor group. Then, pressing the  key causes SV No. to flash. When target SV No. is selected by means of the  or  key and is registered by means of the **ENT** key, the RUN monitor lamp begins to flash and ramp control is executed.

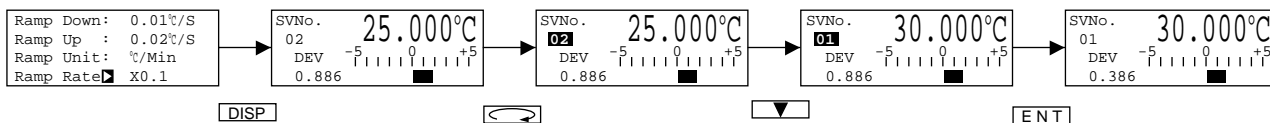

Note 4: A change of mode in 6-1. 4) Setting of mode is not possible during execution of ramp control.

* For temporarily stopping ramp control which is being executed, see 6-8. 5) Temporary stop/restart of ramp control.

6-8. Control group (Group 1)

Press the **GRP** key to call the CONTROL screen (Group 1-0). Then, press the **SCRN** key to move to a screen in which a setting or a change is to be made. Use the **←** key to select a parameter on the screen.

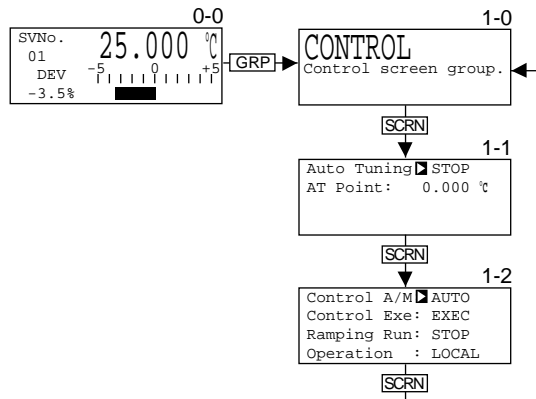

1) Execution/stop of auto tuning (AT) (Group 1-1)

Auto Tuning <input checked="" type="checkbox"/> STOP AT Point: 0.000 °C
--

Setting range: STOP, EXEC
Initial value: STOP

This parameter is used to execute or stop auto tuning (AT).

What is auto tuning (AT)?

Optimum PID constants are automatically calculated by the limit cycle method and control is carried out by using such values.

Conditions for execution (common to front key input and external input)

- (1) Ramp control is not in execution.
- (2) MANUAL is not on.
- (3) P=0 (ON-OFF control) has not been selected.
- (4) STANBY is not on.
- (5) Remote SV is not in use.
- (6) PV value is not over Scale.

Note 1: As output limits affect AT execution, lower limit and higher limit values of control output should be set in 6-6. 8) Setting of output limit before executing AT.

Note 2: Only control output 1 executes AT when DA characteristic (two-stage heating) has been selected in the two output type. (Control output 2 executes AT at 0% or with lower limit output limiter left as it is.)

Note 3: During execution of AT, AT lamp in the front panel flashes and the lamp goes out upon termination or stop of AT.

Note 4: Auto tuning stops when

- (1) Scale Over occurs.
- (2) power goes off.
- (3) time of ON or OFF exceeds about 200 minutes.
- (4) STANBY is selected.
- (5) Exe1 or Exe2 of initialization is executed.

2) Setting of auto tuning point (Group 1-1)

```

Auto Tuning: STOP
AT Point ▣ 0.000 °C
    
```

Setting range: 0~10000 unit
Initial value: 0 unit

If you want to avoid hunting resulting from limit cycle with set SV value in executing auto tuning, set a hypothetical SV value (AT point) to carry out auto tuning at a point apart from the actual SV value.

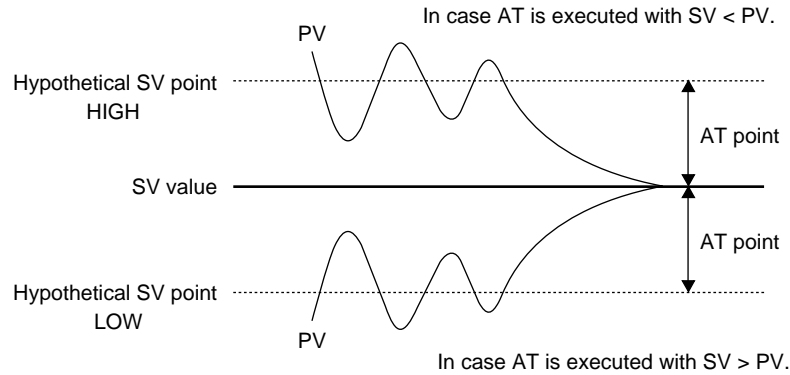

Note 1: AT point is absolute value input of difference between SV value and hypothetical SV value.

Note 2: When 0 is set as AT point, SV value works as AT point.

Note 3: In case PV value is included in AT point, SV value works as AT point.

3) Auto/manual of control output (Group 1-2)

```

Control A/M ▣ AUTO
Control Exe: EXEC
Ramping Run: STOP
Operation : LOCAL
    
```

Setting range: AUTO, MANUAL
Initial value: AUTO

Whether control output is to be operated automatically (AUTO) or manually (MANUAL) can be selected.

- Conditions for execution (common to front key input and external input)
 - (1) Auto tuning is not in execution.
 - (2) STANBY is not on.

Note 1: When MANUAL is selected, the MAN lamp in the front panel flashes.

Note 2: If power is turned off during MANUAL output and turned on again, MANUAL continues.

MANUAL Output Operating Method

When MANUAL is selected on the Control A/M parameter and registered, the MAN lamp in the front panel flashes. To operate control output manually, call the initial screen of the monitor group (Group 0-0) by the use of the **DISP** key. From there, move to the group 0-1 screen of the group by means of the **SCRN** key. Make sure that cursor **▣** is shown in the top left corner of the LCD screen. Then, press the **◀** key to move the flashing figure to a digit whose figure is to be changed and set the value of control output 1 (OUT1) by means of the **▲** and **▼** keys.

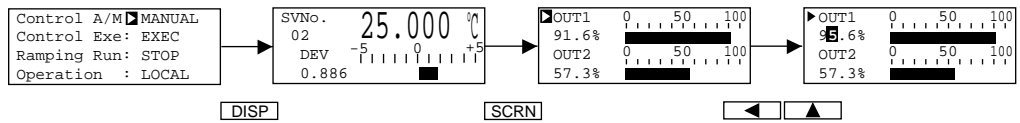

In case optional function of control output 2 (OUT2) is added, move to the OUT2 parameter by means of the **↻** key and set a value in the same way as OUT1.

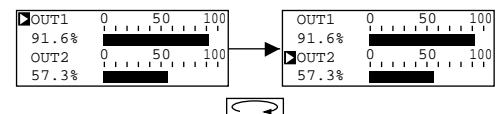

Note 1: In the one output type instrument, neither output value nor output bar graph for OUT2 is shown in the screen.

4) Execution/standby of control (Group 1-2)

Control A/M: AUTO
Control Exe: <input checked="" type="checkbox"/> EXEC
Ramping Run: STOP
Operation : LOCAL

Setting range: EXEC, STANBY
Initial value: EXEC

This is the function to keep control output, event output and external output on standby and to start control only after input is steadied.

STANBY : Control is out of operation and control output is set at 0%.

EXEC : Ordinary control is carried out.

Note 1: Upon selecting STANBY, the STBY lamp in the front panel flashes.

Note 2: Analog output is output even in the state of STANBY.

Note 3: If power is turned off in the state of STANBY and turned on again, STANBY continues.

5) Stop/restart of ramp control (Group 1-2)

Control A/M: AUTO
Control Exe: EXEC
Ramping Run: <input checked="" type="checkbox"/> STOP
Operation : LOCAL

Setting range: STOP, RUN
Initial value: STOP

While ramp control is being carried out, it can be stopped temporarily and restarted.

STOP : Ramp control being executed stops temporarily. The RUN lamp in the front panel lights and the SV display stands still.

RUN : Temporarily stopped ramp control is restarted. The RUN lamp in the front panel flashes and the SV display changes to target SV value.

6) Selection of communication (Group 1-2)

Control A/M: AUTO
Control Exe: EXEC
Ramping Run: STOP
Operation <input checked="" type="checkbox"/> LOCAL

Setting range: LOCAL, (COMM)
Initial value: LOCAL

Whether various data are to be set and changed by front key operation or through communication (optional function) is selected.

LOCAL : Various data are set and changed by front key operation. Setting and changing data through communication is not possible.

COMM : Various data are set and changed through communication. Setting and changing data by front key operation is not possible.

Note 1: For this parameter, selection and setting of COMM ⇔ LOCAL can be made through communication but selection and setting of only COMM ⇒ LOCAL is possible by front key operation.

(For details, please refer to the separate Instruction Manual on Communication Interface.)

Note 2: Screens are not shown if the communication optional functions are not added in your instrument.

6-9. Monitor group (Group 0)

In the monitor group, the states of set value, deviation value and control output are displayed in three screens. In the initial screen of the monitor group (Group 0-0), switch between SV value setting and SV No. in execution is possible.

In case a screen of any other group than the monitor group is on display, press the **DISP** key to call the initial screen of monitor group (Group 0-0). For moving to another screen of the monitor group, use the **SCRN** key.

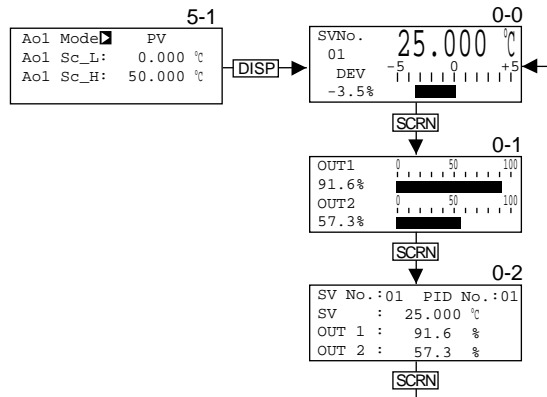

1) Explanation about group 0-0 screen (Group 0-0)

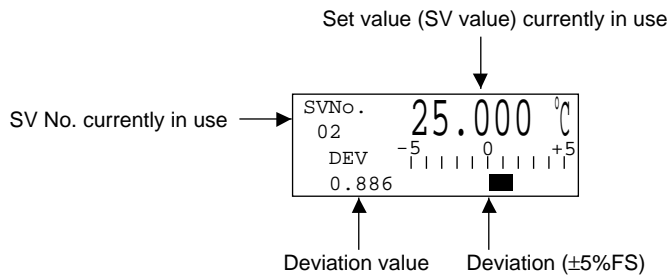

2) Setting of SV value (Group 0-0)

When the **◀** key is pressed in the initial screen of the monitor group, the rightmost digit of the SV value flashes.

Move the flashing figure to a digit whose figure is to be changed, and you can change the SV value of SV No. in execution by pressing the **▲** and **▼** keys. After making sure that the change has been made correctly, register the data by pressing the **ENT** key.

Upon registration, the SV value stops flashing.

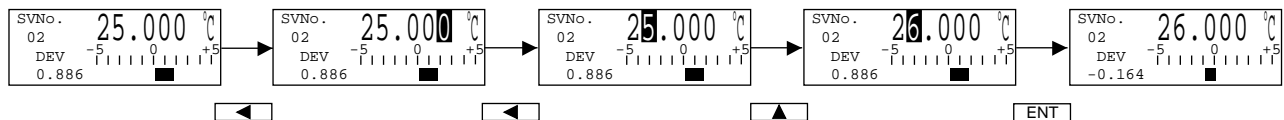

3) Switching of SV No. in execution (Group 0-0)

When the **↻** key is pressed in the initial screen of monitor group, the SV No. flashes, and can be changed by pressing the **▲** and **▼** keys. After making sure that the change has been made correctly, register the data by pressing the **ENT** key. Upon registration, the SV No. stops flashing.

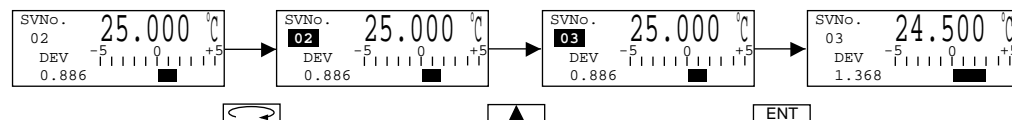

Note 1: In the case of SV Select: EXT (the ESV lamp flashing), SV No. cannot be changed by front key operation.

4) Switching to Remote SV

Switching to Remote SV is available on the initial screen of monitor group. (group 0-0)

In the SV No. in execution of switching, select by using the  key as 01→02→.....→10→REM.

Resistering by  key allows you to switch. However, when remote function is assigned to DI, switching with the SV No. in execution cannot be done.

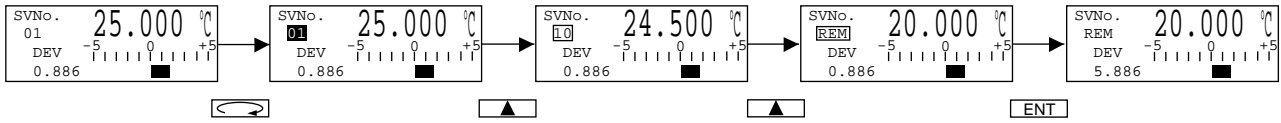

5) Explanation about group 0-1 screen (Group 0-1)

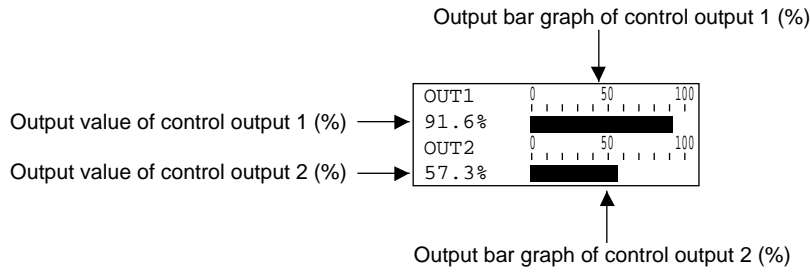

Note 1: In the one output type instrument, neither output value nor output bar graph of OUT2 is shown in the screen.

6) Explanation about group 0-2 screen (Group 0-2)

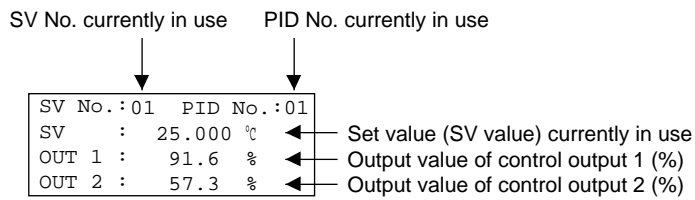

Note 1: In the case of one output type instrument, output value of OUT2 is not shown in the screen.

7. External Input/Output (Option)

External Input

Selection of local SV No. and external control by assigning to DI can be carried out by means of no-voltage contact input signal from external or open collector input signal.

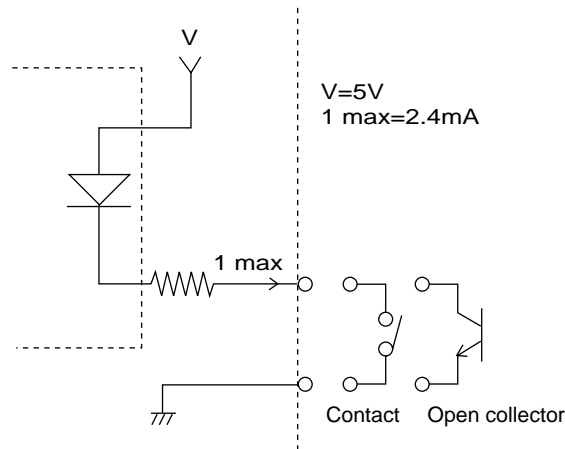

1. Selection of local SV No.

Local SV No. can be selected by external input. In order to use this function, you have to select EXT in 6-7. 3) Setting of selection/switch of multi-SV No. to light the ESV lamp in the front panel.

Example of use:

SV No. can be selected from outside the instrument when 24-pin plug for external input/output (an accessory to this instrument) is used and BIN code digital switch is connected to pin Nos. 12 (COM), 7 (SEL1), 6 (SEL2), 5 (SEL4) and 4 (SEL8).

For 24-pin plug and BIN code digital switch (multi-SV No. switching device), see Chapter 8 Connecting Devices for Instrument Terminals.

If you do not have BIN code digital switch, select SV No. by applying contact signals to 24-pin plug terminals as shown in the following table.

When SV No. 5 is to be selected:

Short across pin Nos. 12 (COM), 7 (SEL1) and 5 (SEL3).

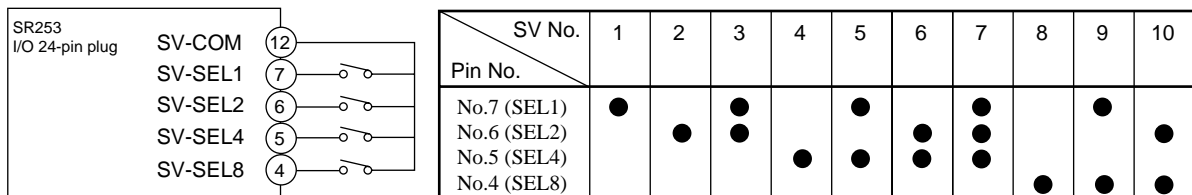

The ● mark shows shorting between the pin No. and COM.

Note 1: When SV No. 0 is selected, it becomes SV No. 1 and selection of any between No. 11 and No.15 makes it SV No. 10.

2. External control

Actions assigned to DIs can be controlled by external no-voltage contact input signal or open collector input signal. To use this function, it is necessary to assign actions to the respective DIs in 6-4. 3) Setting of DI assignment.

Example of use:

Actions assigned from outside the instrument can be controlled when switch is connected to external input/output 24-pin plug Nos.12 (COM), 11 (DO1), 10 (DO2), 9 (DO3) and 8 (DO4) and contact signals are applied.

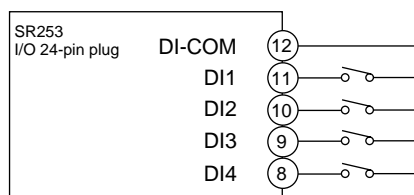

8. Connecting Devices for Instrument Terminals

8-1. 24-pin plug

Pin arrangement of external input/output 24-pin plug:

Pin No.	External contact input	Pin No.	Open collector output	
1	-----	13	-----	
2	-----	14	-----	
3	-----	15	-----	
4	SL SEL8	BIN CODE	16	-----
5	SL SEL4		17	-----
6	SL SEL2		18	-----
7	SL SEL1		19	DO 5
8	DI 4	20	DO 4	
9	DI 3	21	DO 3	
10	DI 2	22	DO 2	
11	DI 1	23	DO 1	
12	SV, DI COM	24	DO COM	

Exterior view of 24-pin plug (available separately) attached with connection cord (with crimp terminal, shielding wire, and mark band).

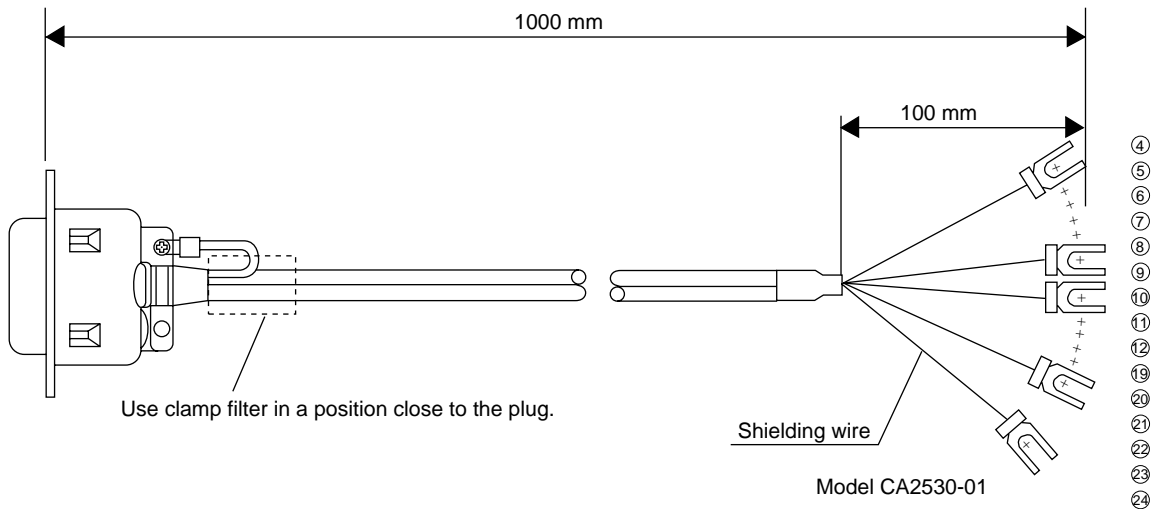

Note 1: If you need connection cords which are longer than 1000 mm, call our local business office.

8-2. Multi-SV No. switching device

Exterior view of multi-SV No. switching device (available separately), terminal arrangement and panel cut-out

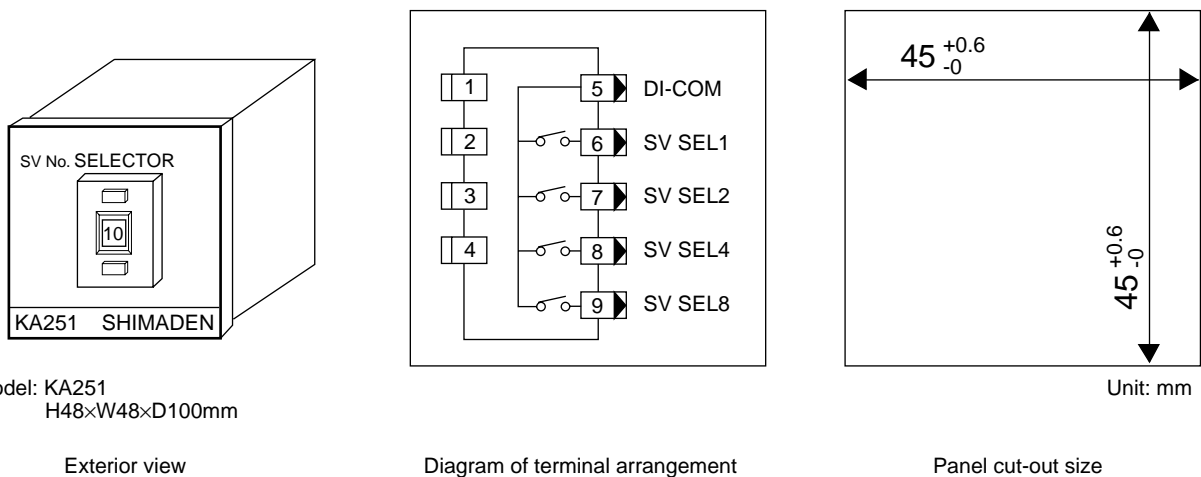

For switching SV No. externally, use this device together with the above-mentioned 24-pin plug attached with connection cords.

9. Error Messages (PV Display)

9-1. Problems found in check-up upon application of power

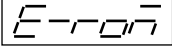
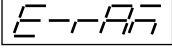
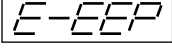
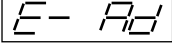
Error message	Cause
	ROM problem
	RAM problem
	EEPROM problem
	A/D problem

Note 1: If any of the messages shown in the table are displayed, repair or replacement will be necessary. Turn the power off as quickly as possible and call the agent or our business office.

Note 2: With the occurrence of any of the problems shown in the table, all outputs turn off or to 0%.

9-2. Problems with PV Input

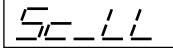
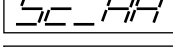
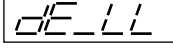
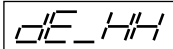
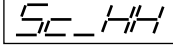
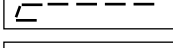
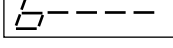
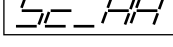
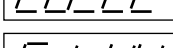
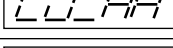
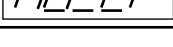
Error message	Cause
	PV value went over lower limit (-10%FS) of measuring range.
	PV value went over higher limit (+110%FS) of measuring range.
	Count fell below lower limit.
	Count exceeded higher limit.
	R.T.D.1 burnt out.
	R.T.D.2 burnt out.
	R.T.D.3 burnt out or more than two points burnt out.
	Thermocouple burnt out.
	In the case of thermocouple input, reference junction compensation is on the lower limit.
	In the case of thermocouple input, reference junction compensation is on the higher limit.
	A/D problem

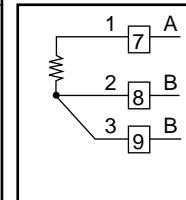

Note 1: If any of the above messages are displayed, check input and CJ.

If nothing is wrong with them, there may be some other cause and you should call the agent or our business office.

Note 2: In case A/D is out of order, it should be dealt with in the same way as when PV or REM goes over their higher limits.

10. List of Parameters

■ Control Group (Group 1)

Control Group	Code	Description of function	Setting range	Initial value
	Auto Tuning ★	Execution/stop of auto tuning	STOP EXEC	STOP
[Key Lock 2]	AT Point ★	Auto tuning point	0~10000 unit	0 unit

Control Group	Code	Description of function	Setting range	Initial value
	Control A/M ★	Auto/manual of control output	AUTO MANUAL	AUTO
	Control Exe	Execution/standby of control	EXEC STANBY	EXEC
	Ramping Run ★	Temporary stop/restart of ramp control	STOP (RUN)	STOP
[Key Lock 2]	Operation	Communication	LOCAL (COMM)	LOCAL

Note 1: Legend:-

[Key Lock 1]: The parameters are locked when Lock1, Lock2 or Lock3 is set.

[Key Lock 2]: The parameters are locked when Lock2 or Lock3 is set.

[Key Lock 3]: The parameters are locked when Lock3 is set.

★: The parameters are initialized when Exe1 is selected in setting of initialization.

■ SV/Remote/Ramp Group (Group 2)

SV Group	Code	Description of function	Setting range	Initial value
[Key Lock 3]	SV_No. 1 ★	Target set value 1	Within set value limiter	0 unit
	SV_No. 2 ★	Target set value 2		
	SV_No. 3 ★	Target set value 3		
	SV_No. 4 ★	Target set value 4		
	SV_No. 5 ★	Target set value 5		
	SV_No. 6 ★	Target set value 6		
	SV_No. 7 ★	Target set value 7		
	SV_No. 8 ★	Target set value 8		
	SV_No. 9 ★	Target set value 9		
	SV_No. 10 ★	Target set value 10		

SV Group	Code	Description of function	Setting range	Initial value
[Key Lock 1]	SV Limt_H ★	Set value limit	Within measuring range but SV_L < SV_H	Lower limit of measuring range
	SV Limt_L ★	Set value limit		Higher limit of measuring range
	SV Select	Selection/switch of Multi-SV No.	KEY EXT	KEY

SV Group	Code	Description of function	Setting range	Initial value
[Key Lock 1]	REM Bias ★	Remote bias	-9999~9999 unit	0 unit
	REM Filt ★	Remote filter	OFF, 1~300	OFF
	REM Sc_L ★	Remote scale	Within measuring range (RSV) 0.00~100.00% (CTRL) but REM Sc_L ≠ REM Sc_H	Lower limit of measuring range 0.00% (CTRL)
	REM Sc_H ★	Remote scale		Higher limit of measuring range 100.00% (CTRL)

SV Group	Code	Description of function	Setting range	Initial value
[Key Lock 1]	REM Mode	Remote mode	RSV CTRL	RSV
	REM Trak	Remote tracking	NO YES	NO
	REM P.B	Remote proportional coefficient	OFF, 0.1~999.9%	OFF
	REM Time	Remote delay time	OFF, 1~9999	OFF

SV Group	Code	Description of function	Setting range	Initial value
[Key Lock 1]	RAMP_Down ★	Downward ramp	OFF, 1~9999	OFF
	RAMP_Up ★	Upward ramp	OFF, 1~9999	OFF
	RAMP_Unit ★	Unit for ramp control	Unit/Sec. Unit/Min.	Unit/Min.
	RAMP_Rate ★	Ramp rate	×1 ×0.1	×1

■ PID Group (Group 3)

PID Group	Code	Description of function	Setting range	Initial value
	P ₁ ★	Proportional band (%)	OFF, 0.1~999.9%	3.0%
	I ₁ ★	Integral time (sec.)	OFF, 1~6000 sec.	120 sec.
	D ₁ ★	Differential time (sec.)	OFF, 1~3600 sec.	30 sec.
	DF ₁ ★	Action hysteresis	1~9999 unit	20 unit
	Zone ★	Setting of zone	Within measuring range	0 unit
	[Key Lock 1]	MR ★	Manual reset	-50.0~50.0%

PID Group	Code	Description of function	Setting range	Initial value
	P ₂ ★	Proportional band (%)	OFF, 0.1~999.9%	3.0%
	I ₂ ★	Integral time (sec.)	OFF, 1~6000 sec.	120 sec.
	D ₂ ★	Rate time (sec.)	OFF, 1~3600 sec.	30 sec.
	DF ₂ ★	Action hysteresis	1~9999 unit	20 unit
	[Key Lock 1]	DB ★	Dead band	-20000~20000 unit

PID Group	Code	Description of function	Setting range	Initial value
	m_O ₁ , Lmt_L	Lower limit value of output 1 limit	-5.0~104.9%	0.0%
	m_O ₁ , Lmt_H	Higher limit value of output 1 limit	-4.9~105.0%	100.0%
	m_O ₂ , Lmt_L	Lower limit value of output 2 limit	-5.0~104.9%	0.0%
	m_O ₂ , Lmt_H	Higher limit value of output 2 limit	-4.9~105.0%	100.0%
[Key Lock 1]				

m=1~10

PID	Code	Description of function	Setting range	Initial value
	Zone HYS ★	Zone hysteresis	0~10000 unit	20 unit
	Zone PID ★	Zone PID mode	Singl Zone	Singl
	REM PID ★	Remote PID No.	01~10	01
	[Key Lock 1]	SF ★	Target value function	0.00~1.00

■ EVENT/DO Group (Group 4)

EVENT/DO Group	Code	Description of function	Setting range	Initial value
Event 1 Event 2 Event 3 DO 1 DO 2 DO 3 DO 4 DO 5	Mode	Action mode	DEV High DEV Low DEV Outside DEV Inside PV High PV Low SV High SV Low Auto Tuning Manual Remote Run Stanby Scale Over PV Scale Over REM Scale Over Direct HBA (with heater break alarm option) HLA (with heater loop alarm option)	EV1: DEV High EV2: DEV Low EV3: Scale Over (HBA) DO1: Auto Tuning DO2: Manual DO3: Remote DO4: Run DO5: Stanby
	Set Point ★	Action set point (only for DEV, PV and SV)	DEV High : 0~25000 unit DEV Low : -25000~0 unit DEV Outside: 0~25000 unit DEV Inside : 0~25000 unit PV High : within measuring range PV Low : within measuring range SV High : within measuring range SV Low : within measuring range	D H : 25000 unit D L : -25000 unit D O : 25000 unit D I : 25000 unit P H : Higher limit value of measuring range P L : Lower limit value of measuring range S H : Higher limit value of measuring range S L : Lower limit value of measuring range
	Diffrentl ★	Action hysteresis (only for DEV, PV and SV)	1~9999 unit	20 unit
	Delay	Delay time (only for DEV, PV and SV)	OFF, 1~9999 sec.	OFF
	Inhibit	Inhibit action (only for DEV, PV and SV)	OFF ON	OFF
	[Key Lock 1]	Charact	Output characteristics (only for DEV, PV and SV)	Open Close

■ OPTION Group (Group 5)

OPTION Group	Code	Description of function	Setting range	Initial value
Analog Out1	Ao1 Mode	Analog output 1 assignment	PV SV DEV OUT1 OUT2	PV
	Ao1 Sc_L ★	Analog output 1 scaling	Within measuring range (PV and SV) -100.0~100.0% (DEV) 0~100.0% (OUT1 and OUT2), but Ao1 Sc_L ≠ Ao1 Sc_H	Lower limit value of measuring range
	Ao1 Sc_H ★	Analog output 1 scaling		Higher limit value of measuring range
[Key Lock 1]				

OPTION Group	Code	Description of function	Setting range	Initial value
Analog Out2	Ao2 Mode	Analog output 2 assignment	PV SV DEV OUT1 OUT2	SV
	Ao2 Sc_L ★	Analog output 2 scaling	Within measuring range (PV and SV) -100.0~100.0% (DEV) 0~100.0% (OUT1 and OUT2), but Ao2 Sc_L ≠ Ao2 Sc_H	Lower limit value of measuring range
	Ao2 Sc_H ★	Analog output 2 scaling		Higher limit value of measuring range
[Key Lock 1]				

OPTION Group	Code	Description of function	Setting range	Initial value
DIm m=1~4	DI1	DI1 assignment	Nop Manual Remote Auto Tune Standby Dir Act. Stop Direct	Nop
	DI2	DI2 assignment		
	DI3	DI3 assignment		
	DI4	DI4 assignment		
[Key Lock 1]				

OPTION Group	Code	Description of function	Setting range	Initial value
Heat Brak	HBA Curr	Heater break alarm current value	OFF, 0.1~50.0A	OFF
	HLA Curr	Heater loop alarm current value	OFF, 0.1~50.0A	OFF
	HA Mode	Heater break/loop alarm mode	LOCK REAL	LOCK
[Key Lock 1]				

OPTION Group	Code	Description of function	Setting range	Initial value
Commu (Address) (bps) (Data) (Mode)	Addr	Machine address	00~99	01
	BPS	Communication rate	1200 bps 2400 bps 4800 bps 9600 bps 19200 bps	1200 bps
	DATA	Length of data, parity	7E1 7E2 7N1 7N2 8E1 8E2 8N1 8N2	7E1
	Mode	Communication protocol mode	SR25 Mode	(Standard) SR25 Mode
[Key Lock 1]				

OPTION Group	Code	Description of function	Setting range	Initial value
	MEM	Communication memory mode	EEP RAM	EEP
	CTRL	Control code (Standard mode only)	STX_ETX_CR STX_ETX_CRLF @_:_CR	STX_ETX_CR
	BCC	Check sum (Standard mode only)	Add Add-two's cmp XOR NONE	Add
[Key Lock 1]	DELY	Delay	0~99	40

■ Output Group (Group 6)

OUTPUT Group	Code	Description of function	Setting range	Initial value
	Out Actn	Output characteristics	Rev Act. Dir Act.	Rev Act.
	Out1 Cyc	Output 1 cycle	1~200 sec.	30 sec. (Contact) 3 sec. (SSR)
[Key Lock 1]	Out2 Cyc	Output 2 cycle	1~200 sec.	30 sec. (Contact) 3 sec. (SSR)

OUTPUT Group	Code	Description of function	Setting range	Initial value
	Err_Out1	Output 1 in case of Scale Over	-0.5~105.0%	0.0%
[Key Lock 1]	Err_Out2	Output 2 in case of Scale Over	-0.5~105.0%	0.0%

■ Unit/Measuring Range Group (Group 7)

UNIT/RANGE Group	Code	Description of function	Setting range	Initial value
[Key Lock 1]	PV Bias ★	PV bias	-9999~9999 unit	0 unit
	PV Filt ★	PV filter	OFF, 1~300	OFF
	Pt Type	Type of R.T.D.	Pt100 JPt100	Pt100
	CJ Comp	Reference junction compensation	INTER EXTER	INTER

UNIT/RANGE Group	Code	Description of function	Setting range	Initial value
[Key Lock 1]	Unit	Measurement unit	°C °F % (Only for linear input) K (Only for thermocouple) BRK (Only for linear input)	°C
	Figur	Rounding of fraction in lowest decimal place	YES NO	YES
	Range	Measuring range	1~17 (thermocouple) 18~19 (thermocouple, kelvin) 1~16 (R.T.D.) 1~7 (voltage mV) 1~7 (voltage V) 4~5 (Current mA)	6 (thermocouple) 18 (thermocouple) 14 (R.T.D.) 2 (voltage mV) 6 (voltage V) 5 (Current mA)

UNIT/RANGE Group	Code	Description of function	Setting range	Initial value
[Key Lock 1]	PV D.P.	Position of decimal point	XXXXXX XXXX.X XXX.XX XX.XXX X.XXXX	XXXX.X
	PV Sc_H	Scale on higher limit side	-19999~26000 unit (Minimum span 100 unit) (Maximum span 25000 unit) but Sc_L < Sc_H	0 unit
	PV Sc_L	Scale on lower limit side		1000 unit

■ Lock/Initialization Group (Group 8)

LOCK/INIT Group	Code	Description of function	Setting range	Initial value
[Key Lock 1]	Key Lock	Key lock (The key lock parameter is not locked.)	OFF LOCK1 (excluding SV and CONTROL) LOCK2 (excluding SV) LOCK3 (all parameters)	OFF
	Disp Ret	Time for screen to reappear	OFF, 10~120 sec.	60 sec.
	Initial	Initialization	None EXE1 (Parameters marked with *) EXE2 (All including those marked with *)	None

LOCK/INIT Group	Code	Description of function	Setting range	Initial value
[Key Lock 1]	Mode	Mode	One output: 00, 02 Two outputs: 00, 01, 02, 03	02 (for one output type) 03 (for two output type)

11. Sheet for Recording Set Parameters

SV/Remote/Ramp setting group (Group 2) and PID setting group (Group 3)

		User set value								Multi-SV No.	
		1	2	3	4	5	6	7	8	9	10
SV set value											
PID set value (output 1)	P ₁										
	I ₁										
	D ₁										
	ZONE										
	DF ₁										
	MR										
Set value for output limits (output 1)	Lmt_L										
	Lmt_H										
PID set value (output 2)	P ₂										
	I ₂										
	D ₂										
	ZONE										
	DF ₂										
	DB										
Set value for output limits (output 2)	Lmt_L										
	Lmt_H										

Item	User set value
SV Limt_L	
SV Limt_H	
SV Select	
REM Bias	
REM Filt	
REM Sc_L	
REM Sc_H	
REM Mode	
REM Trck	
REM P.B	
REM Time	
RAMP Down	
RAMP Up	
RAMP Unit	
RAMP Rate	

Item	User set value
Zone HYS	
Zone PID	
REM PID	
SF	

Output group (Group 6)

Item	User set value
Out Actn	
Out1 Cyc	
Out2 Cyc	
Err Out1	
Err Out2	

Unit/Measuring range setting group (Group 7)

Item	User set value
PV Bias	
PV Filt	
Pt Type	
CJ Comp	
Unit	
Figur	
Range	
PV D.P.	
PV SCL	
PV SCH	

Lock/Initialization group (Group 8)

Item	User set value
MODE	

EVENT/DO setting group (Group 4)

	Item	User set value
EV 1	Mode	
	Set Point	
	Diffrentl	
	Delay	
	Inhibit	
	Charact	
EV 2	Mode	
	Set Point	
	Diffrentl	
	Delay	
	Inhibit	
	Charact	
EV 3	Mode	
	Set Point	
	Diffrentl	
	Delay	
	Inhibit	
	Charact	

Option group (Group 5)

Item	User set value
Ao1 Mode	
Ao1 SC_L	
Ao1 SC_H	
Ao2 Mode	
Ao2 SC_L	
Ao2 SC-H	
DI1	
DI2	
DI3	
DI4	
HBA Curr	
HLA Curr	
HA Mode	
Addr	
Mode	
MEM	
CTRL	
BCC	
DELY	

	Item	User set value
DO 1	Mode	
	Set Point	
	Diffrentl	
	Delay	
	Inhibit	
	Charact	
DO 2	Mode	
	Set Point	
	Diffrentl	
	Delay	
	Inhibit	
	Charact	
DO 3	Mode	
	Set Point	
	Diffrentl	
	Delay	
	Inhibit	
	Charact	
DO 4	Mode	
	Set Point	
	Diffrentl	
	Delay	
	Inhibit	
	Charact	
DO 5	Mode	
	Set Point	
	Diffrentl	
	Delay	
	Inhibit	
	Charact	

12. Specifications

1. Display

- LED display: 7-segment green LED 5 digits/height of character 14 mm
Measured value (PV) display
- LCD display: 128×32 full dot matrix liquid crystal display
(Basic display 21 digits, 4 lines with LED back light)
Set value (SV), SV No. display and set parameter display
- LED lamp indication: Action (status) display 16 types for 1 output, 17 types for 2 outputs
AT, MAN, STBY, RUN, ESV, REM, COM, EV1, EV2, EV3, DO1, DO2, DO3, DO4, DO5,
OUT1, OUT2
- Display accuracy: TC input: $\pm(0.1\%FS+1^{\circ}C)$
Pt input: $\pm(0.1\%FS+0.1^{\circ}C)$
mV, mA input: $\pm(0.1\%FS+1 \text{ digit})$
- Temperature range for maintaining accuracy: $23^{\circ}C\pm 5^{\circ}C$
- Display resolution: Depends on measuring range and scaling (0.0001/0.001/0.01/0.1/1)
- Sampling cycle: 200 msec. (0.2 sec.)

2. Setting

- Local setting: By 8 front key switches
Setting range: Same as measuring range
Multi SV value setting: Setting of 10 points maximum possible
Multi SV value setting: Selectable by front key switches or DI input (binary code)
Higher and lower limit setting limiter: Higher/lower limit individual setting as desired within measuring range
(lower limit value < higher limit value)
- Remote setting: By external analog signals
Not insulated/standard (0~10V); Insulated/optional
Setting accuracy: $\pm(0.1\%FS+1 \text{ digit})$
Setting signal: 0~10V, 1~5V DC, 4~20mA DC/Selectable from code selection table
Sampling cycle: 3 times/sec. (200/400 msec.)
Remote scaling: Possible within measuring range (inverse scaling possible)
Remote bias: $\pm 9999 \text{ unit}$
Remote filter: OFF, 1~300 Sampling cycle (Approx. 1/3 sec.)
- Local/remote switching: By front key switch or external operation
- Direct tracking function: Remote set value switchable to local set value bumplessly
- Ramp control: Increment/Decrement control
Setting range: 1~9999 unit/min. or sec. individual setting (0.1~999.9 unit/min. or sec. individual setting)

3. Input

- Thermocouple: B, R, S, K, E, J, T, N, PLII, PR40-20, WRe5-26, {L, U (DIN) 43710}
Gold & iron-Chromel (multi input, multi range)
External resistance allowable range: 100 max.
Influence of external resistance: $1\mu V/10$
Input impedance: 500k min.
Burnout function: Standard feature (up scale)
Reference junction compensation: Selectable between internal reference junction compensation/external reference junction compensation
Internal reference junction compensation accuracy: $\pm 1.0^{\circ}C$ (within range from 18 to 28°C)

- R.T.D.: JIS Pt/JPt 3-wire type (multi range)
 - Lead wire tolerable resistance: 5 max./wire
 - Amperage: Approx. 1mA
- Voltage: -10~10, 0~10, 0~20, 0~50, 10~50, 0~100, -100~100mV DC or -1~1, 0~1, 0~2, 0~5, 1~5, 0~10, -10~10V DC (Multi input, programmable scaling)
 - Input impedance: 500k min.
- Current: 4~20, 0~20mA DC (Multi input, programmable scaling)
 - Receiving impedance: 250
- PV bias: ±9999 unit
- PV filter: OFF, 1~300 sampling cycle (0.2 sec.)
- Isolation: Insulated between input and DI input, outputs insulated from each other (not insulated between input and system, remote input and CT input)

4. Control

- Control mode:
 - In case of 1 output: Expert PID control with auto tuning function
 - In case of 2 outputs: Expert PID+PID control with auto tuning function
 - During RA - Heating/cooling action
 - During DA - Heat + heat action
- Control output 1
 - Multi PID: By PID No. 01~10 (10 types)
 - Control output 1 proportional cycle: 1~200 sec. (in case of contact or SSR drive voltage output)
- Control output 2 (applicable only to apparatus with optional function of 2 outputs)
 - Multi PID: By PID No. 01~10 (10 types)
 - Control output 2 proportional cycle: 1~200 sec. (in case of contact or SSR drive voltage output)
- Control output type/rating:
 - Contact output: 240V AC/2.5A (resistive load)
 - Current output: 4~20mA DC/load resistance: 600 max.
 - SSR drive voltage: 12±1.5V DC/load current: 30mA max.
 - Voltage output: 0~10V DC/ load current: 2mA max.
 - Output resolution: Approx. 1/8000 (with current/voltage output)
 - Output accuracy: ±0.5%FS (5~100% output/within accuracy maintaining temperature range)
- Operation/output updating cycle: 200 msec.
- Multi PID: Individual PID (10 types) setting for each SV No. and Remote SV. Zone PID, i.e., PID setting for each zone of SV values is also possible.
 - Zone PID mode: Selectable between individual PID and zone PID
 - Control output 1
 - Proportional band: Off, 0.1~999.9% (Off setting: On-Off action)
 - Integral time: Off, 1~6000 sec. (Off setting: With manual reset)
 - Derivative time: Off, 1~3600 sec.
 - Action hysteresis: 1~9999 unit (during On-Off action)
 - Control output 2
 - Proportional band: Off, 0.1~999.9% (Off setting: On-Off action)
 - Integral time: Off, 1~6000 sec.
 - Derivative time: Off, 1~3600 sec.
 - Action hysteresis: 1~9999 unit (during On-Off action)
 - Dead band: -20000~20000 unit
- Higher/lower output limiter: Higher limit/lower limit (to be set on every individual PID)
 - Setting range: -5.0~105.0% (lower limit < higher limit)
- Control output characteristics: RA/DA switchable by front key switch or external control input (DI)
- External control input: Remote input usable as external control input
 - Remote mode: Remote SV input/external control input selectable
 - Remote proportional coefficient: Off, 0.1~999.9%
 - Remote primary delay time: Off, 1~9999 sec.

- Manual control
 - Output setting range: Y, P: 0.0~100.0%, I, V: -5.0~105.0%
 - Output resolution: 0.1%
 - Auto/manual switch: Balanceless bumpless action (within proportional band range)
Switching by front key switch or external control input (DI)
- Isolation: Insulated between control output and various inputs/outputs and system
(not insulated between 1 output and 2 outputs)

5. Event Output (Option)

- The number of outputs: Total 3 points, from EV1 to EV3
- Output rating: Contact output 240V AC/1.0A (resistive load)
- Setting/selection: Individual setting (individual output)/Selectable from following 19 types (output designation)
 - 1) DEV : Higher limit (deviation value action)
 - 2) DEV : Lower limit (deviation value action)
 - 3) DEV : Out of range (deviation value action)
 - 4) DEV : Within range (deviation value action)
 - 5) PV : Higher limit (absolute value action)
 - 6) PV : Lower limit (absolute value action)
 - 7) SV : Higher limit (absolute value action)
 - 8) SV : Lower limit (absolute value action)
 - 9) AT : Auto turning in execution ON
 - 10) MAN : In manual operation ON
 - 11) REM : In remote operation ON
 - 12) RUN : Ramp control in execution ON
 - 13) STBY : Control action not in execution ON
 - 14) SO : Scale-over of PV and REM ON
 - 15) PV SO : Scale-over of PV ON
 - 16) REM SO : Scale-over of REM ON
 - 17) DIR : During direct output ON
 - 18) HBA : During heater break alarm output ON (option)
 - 19) HLA : During heater loop alarm output ON (option)

*) DEV, PV and SV events allow the following setting:

Hysteresis : 1~9999 unit
 Inhibit action : With/without selectable
 Action delay : Off, 1~9999 sec.

Switching of output

characteristics : Individually selectable between normal open and normal close

- Isolation: Insulated between EV outputs and various inputs and system; various outputs insulated from each other

6. DI Input/DO Output (Optional in common)

- The number of DI inputs: Multi SV selection 4 points, control inputs 4 points (Total 8 points)
- DI input type: Exclusive use for multi SV selection (binary input)
Selective setting from 8 types; NOP, AT, MAN, REM, STOP, STBY, DA, DIR
- DI input rating: Non-voltage contact, open collector input
- The number of DO outputs: 5 points from DO1 to DO5
- DO output type: Individual setting/individual output (Selective designation from 19 types)
(Details are the same as EV option)
- DO output rating: Open collector output 24V DC/50mA max.
- Isolation: Insulated between DI input/DO output and various inputs and system; various outputs insulated from each other (not insulated between DI input and DO output)

7. Heater Break Alarm (Option)

- Alarm action: Heater amperage detected by externally attached CT (special CT provided) (single phase)
Alarm output On upon detection of heater break while control output is On.
Alarm output On upon detection of heater loop alarm while control output is Off.
- Setting
 - Current setting range: Off, 0.1~50.0A (Off setting: HB or HL alarm action stops)
 - Setting resolution: 0.1A
- Display
 - Amperage display: 0.0~55.0A
 - Display accuracy: 3% FS (When sine wave is 50Hz)
- Output holding: Selectable between holding mode and real mode
- Sampling cycle: 1 sec.
- Minimum time for action confirmation: 250 msec. min. (every second) both at On time and Off time
- Isolation: Isolated between CT input and DI input; various outputs insulated from each other (not insulated between sensor input and remote input and system)
- Output method: Assigned to event outputs

8. Analog Output (Option)

- The number of analog outputs : Maximum 2 points (individual setting/individual output)
- Analog output type: Selectable from PV, SV, DEV, OUT1 and (OUT2)
- Output rating:
 - 0~10mV DC / output resistance: 10
 - 0~10V DC / load current: 1mA max.
 - 4~20mA DC / load resistance: 300 max.
- Output accuracy: $\pm 0.1\%$ FS (of displayed value)
- Output resolution: Approx. 0.01% (1/10000)
- Output updating cycle: 200 msec. (0.2 sec.)
- Output scaling: Within measuring range (inverse scaling possible)
- Isolation: Insulated between analog outputs and various inputs and system; various outputs insulated from each other (analog outputs not insulated from each other)

9. Communication Function (Option)

- Communication type: RS-232C, RS-422A and RS-485
- Communication system: Half duplex start-stop synchronization system
- Communication rate: 1200, 2400, 4800, 9600 and (19200) bps
- Data bit length: Selectable from 7 bits, 8 bits, no parity and even parity
- Communication address: 0~99
- Communication code: ASCII code
- Communication protocol: SR25-conforming protocol
- Others: Delay time selectable, memory mode selectable
- Isolation: Insulated between communication signals and various inputs and system; various outputs insulated from each other

10. General Specification

- Data storage: By non-volatile memory (EEPROM)
- Operating ambient temperature/humidity range: -10~50°C/90% RH max. (no dew condensation)
- Storing temperature: -20~+65°C
- Supply voltage: 100V-240V AC±10% (50/60Hz)
- Power consumption: Maximum 15 VA
- Input noise removal ratio: Normal mode: 60 dB minimum (50/60Hz)
Common mode: 140 dB minimum (50/60Hz)
- Applicable standards: Safety: IEC1010-1 and EN61010-1
EMC: EN55011: Class A Group 1 (EMI/emission)
EN50082-2: 1995 (EMS/immunity)
During EMC testing, the apparatus continues to operate at a measurement accuracy within ±2% of the range.
- Insulation resistance: Between input/output terminal and power supply terminal: 500V DC 20 M minimum
Between input/output terminal and ground terminal: 500V DC 20 M minimum
- Dielectric strength: 1 min. at 2300V AC between input/output terminal and power supply terminal (Responsive current 5mA)
1 min. at 2300V AC between power supply terminal and ground terminal (Responsive current 5mA)
- Protective structure: The front operating panel is dust-proof and drip-proof. (equivalent to IP65)
- Material of case: PPO resin molding (equivalent to UL94V-1)
- External dimensions: H96×W96×D138 (panel depth : 125) mm
When terminal cover is used: (panel depth : 130) mm
When direct type plug is used: (panel depth : 180) mm
- Mounting: Push-in panel (one-touch mount)
- Panel thickness: 1~4.5 (Panel thicker than 4.5 mm can be mounted by means of mounting metal fittings.)
- Size of mounting hole: H92×W92
- Weight: Approx. 600g

Distributed in New Zealand by:

Intech INSTRUMENTS LTD

Christchurch	Auckland	www.intech.co.nz
Ph: +6433430646	098271930	sales@intech.co.nz
Fx: +6433430649	098271931	

The contents of this manual are subject to change without notice.

Temperature and Humidity Control Specialists
SHIMADEN CO., LTD.

Head Office: 2-30-10 Kitamachi, Nerima-Ku, Tokyo 179-0081 Japan
Phone: +81-3-3931-7891 Fax: +81-3-3931-3089
E-MAIL: exp-dept@shimaden.co.jp URL: <http://www.shimaden.co.jp>

PRINTED IN JAPAN